

**Electric Actuators
ELEWAVE SERIES**

Low Profile Electric Slider



**Compact and
highly accurate**

Low profile, high rigidity, high accuracy

Low Profile Electric Slider EW2G

Compact DC brushless motor combined with Koganei's highly reliable Mini Guide Slider series.

- First in the industry: Low profile, high rigidity, high accuracy actuator

Low profile

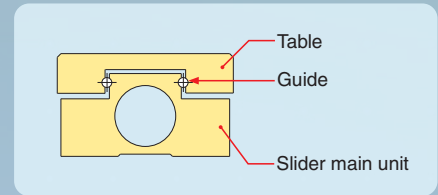

EW2G10: **16 mm**
[0.630 in.]

EW2G12: 18 mm [0.709 in.]

EW2G16: 23 mm [0.906 in.]

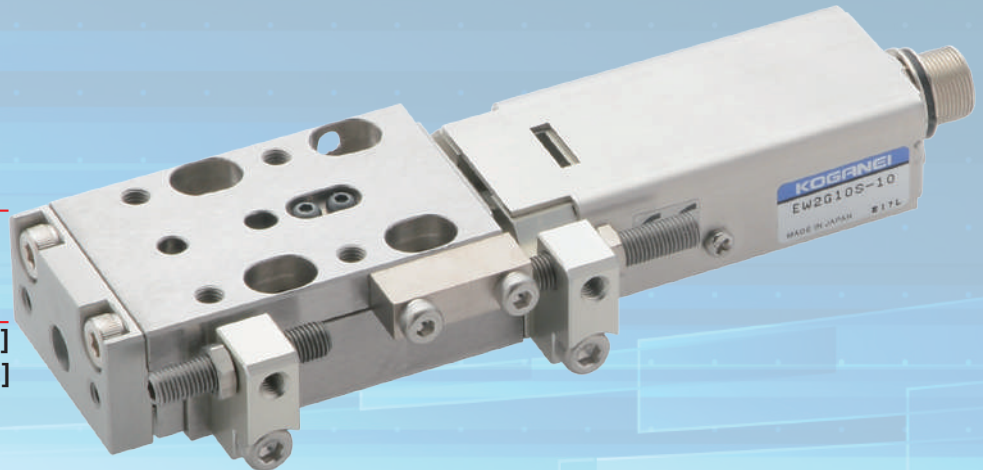

High accuracy

Traveling parallelism

0.005 mm [0.0002 in.]^{Note}

Mounting parallelism

0.03 mm [0.001 in.]^{Note}

Note: Depends on the stroke.
For details, see page ⑦.

High rigidity

Allowable moment

Pitching : 2.1 N·m [18.587 in·lbf]^{Note}

Yawing : 2.5 N·m [22.128 in·lbf]^{Note}

Rolling : 4.3 N·m [38.059 in·lbf]^{Note}

Note: For EW2G16. For details, see page ⑦.

- Intermediate stops, speed control, and thrust settings are possible.

High accuracy positioning is possible by using external stopper (stroke adjustment mechanism).

Repeatability of stopping accuracy is ±0.005 (when using external stopper)

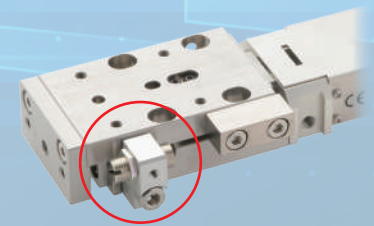

- Simple operation mode of just ON and OFF is available.

Control similar to an air cylinder is possible.

- Mounting compatibility with Mini Guide Slider.

Note: Some pin hole positions are different.

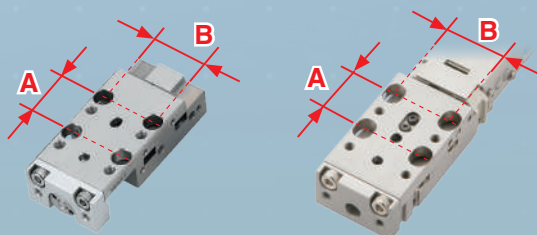

INDEX

Specifications and order codes	9
EW2G10 (Motor size 10) dimension diagrams	13
EW2G12 (Motor size 12) dimension diagrams	18
EW2G16 (Motor size 16) dimension diagrams	23
Controller	28
Selection Procedure	36
Teaching box (EW2TB)	38

High torque type EW2G□S

Motor size $\phi 10$ [0.394] · $\phi 12$ [0.472] · $\phi 16$ [0.630]

Maximum thrust $\phi 10$ [0.394]: 20 N [4.496 lbf]
 $\phi 12$ [0.472]: 40 N [8.992 lbf]
 $\phi 16$ [0.630]: 60 N [13.488 lbf]

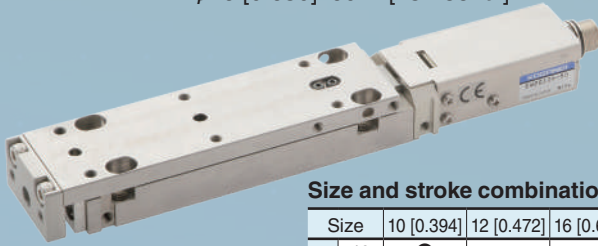

Size and stroke combinations

Size	10 [0.394]	12 [0.472]	16 [0.630]
Stroke	10	●	-
	20	-	●
	30	●	-
	40	-	●
	50	●	-
	60	-	●
	80	-	●
	100	-	●

High speed type EW2G□H

Motor size $\phi 10$ [0.394] · $\phi 12$ [0.472] · $\phi 16$ [0.630]

Maximum speed: 100 mm/s [3.937 in/sec]



Size and stroke combinations

Size	10 [0.394]	12 [0.472]	16 [0.630]
Stroke	10	●	-
	20	-	●
	30	●	-
	40	-	●
	50	●	-
	60	-	●
	80	-	●
	100	-	●

Variations

1. Measures against foreign objects Specifications to protect the slide screws are available.

● EW2G□

Standard specification^{Note}



● EW2G□C

Cover specification



● EW2G□R

Fixed table specification

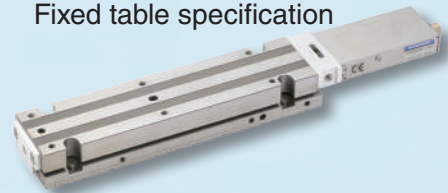

Note: The standard specifications do not have measures against foreign objects. See "Environment" in General precautions on page 6.

2. Stroke adjustment mechanism (Attached)

- Blank: No stroke adjustment mechanism
- MS2 : Metal stoppers on both sides (2 pc. Attached)
- MSF : Metal stopper on OUT side (1 pc. Attached)
- MSR : Metal stopper on IN side (1 pc. Attached)



Note 1: Stroke adjustment mechanisms to be installed by customer.

Note 2: Photo shows after -MS2 has been installed.

Note 3: Measure against foreign objects EW2G□R cannot be selected.

3. Vertical bracket There are 3 brackets available for mounting actuator vertically. (Attached)

● EW2G-BK1

(Bracket 1)

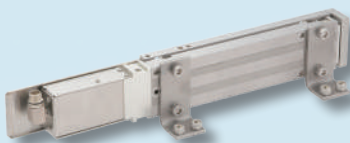

● EW2G-BK2

(Bracket 2)



● EW2G-BK3

(Bracket 3)



Features	Bracket 1	Bracket 2	Bracket 3
Cost	●	□	□
Installability	●	●	□
Rigid (accurate)	□	●	●
Small pitch	□	□	●

Note: Measure against foreign objects EW2G□R cannot be selected.

Low profile, high rigidity, high accuracy

Low Profile Electric Slider

Controller

● **CC-Link Remote device type**

CC-Link



● **CC-Link Remote I/O type**

CC-Link



● **Point input type (NPN specifications, PNP specifications)**



Various settings	CC-Link, teaching box, or support software	Teaching box or support software	Teaching box or support software
Operation commands	CC-Link	CC-Link	I/O

Applicable examples

Connector continuity inspections

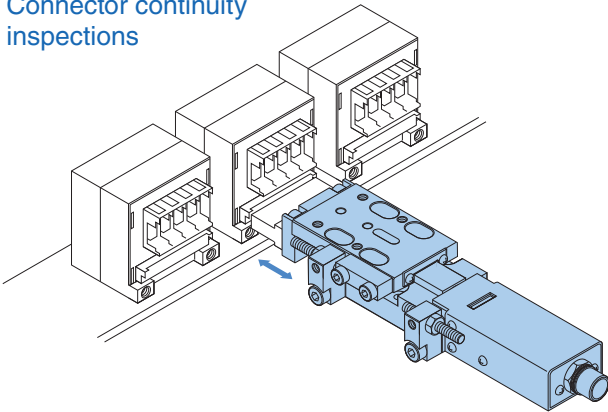

Circuit board positioning clamp

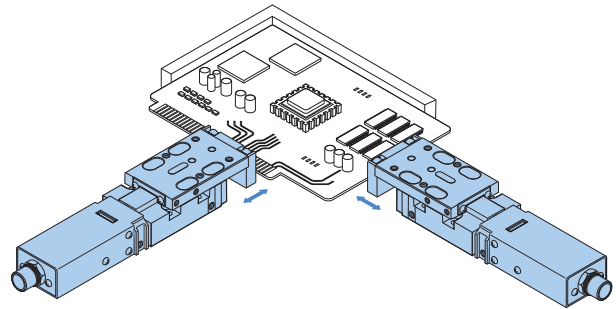



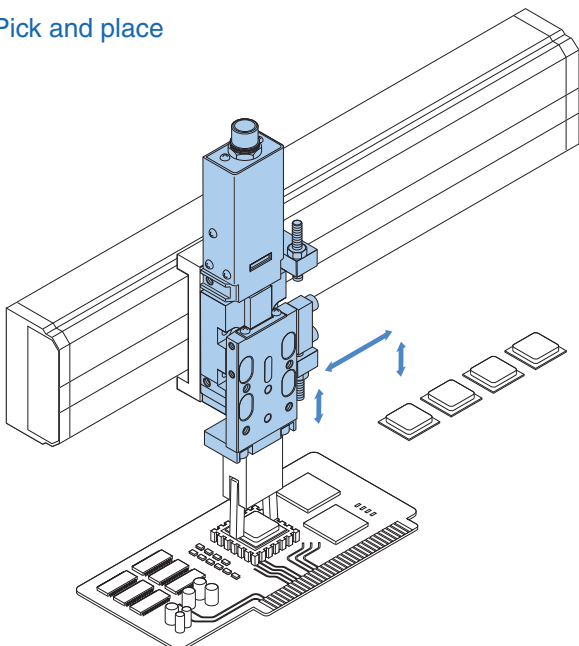

Pick and place



Before selecting and using an appropriate product, please read all the safety precautions carefully to ensure proper product use. These safety precautions are designed to help you use the product safely and correctly, and to prevent injury or damage to you and others, and to prevent material damage.
 Be sure to adhere to the safety regulations in JIS B 8433 (Safety requirements for industrial robots).

The directions are classified according to the degree of potential danger or damage as **DANGER, WARNING, CAUTION, and ATTENTION.**

 DANGER	Indicates situations that can be clearly predicted as dangerous. Death or serious injury may result if the situation is not avoided. It could also result in damage or destruction of assets.
 WARNING	Indicates situations that, while not immediately dangerous, could become dangerous. Death or serious injury may result if the situation is not avoided. It could also result in damage or destruction of assets.
 CAUTION	Indicates situations that, while not immediately dangerous, could become dangerous. Minor or semi-serious injury may result if the situation is not avoided. It could also result in damage or destruction of assets.
 ATTENTION	Indicates no risk of injury, but gives points that should be observed for proper use of the product.

- This product was designed and manufactured as a part for use in general industrial machinery.
- Before selecting or handling this equipment, a system designer or other person with sufficient knowledge and experience should first read the "Safety Precautions", "Catalog", "Owner's Manual" and other documentation. Handling errors create dangerous situations.
- The customer is responsible for all verification and decisions concerning the compatibility of this product with the customer's system.
- After reading the instruction manual, catalog, and other documentation, always store them in a location that allows easy availability for reference to users of this product.
- Whenever transferring or lending the product to another person, always attach the catalog, instruction manual, and other information to the product where they are easily visible in order to ensure that the new user can use the product safely and properly.
- The danger, warning and caution items listed in these safety precautions do not cover all possible contingencies. Read the catalog and instruction manual carefully, and always keep safety first.

 **Danger**

- Do not use the product for the purposes listed below:
 1. Medical equipment related to maintenance or management of human life or health
 2. Machines or equipment designed for the purpose of moving or transporting people
 3. Critical safety components in mechanical devices
 This product has not been planned or designed for purposes that require high levels of safety. There is a risk of loss of human life.
- Do not use the product in locations with dangerous substances such as flammable or ignitable substances. There is a risk of ignition and fire.
- Do not enter the machinery's operating area while the product is in operation, or while it is in an operation-ready state. In addition, do not make any adjustments to the interior or to the attached mechanism of the product in operation. The actuator may move suddenly, resulting in injury.
- Users of pacemakers or other similar medical devices should maintain a distance of at least 1 meter from the product. Getting too close to the product creates the risk of malfunction of a pacemaker due to the strong magnet built into the product.
- When mounting the product, always make sure it is firmly supported and secured (including the workpiece). If the product tips over, drops, or malfunctions, there is a risk of personal injury.
- Never modify the product. Doing so can cause malfunctions and create the risk of personal injury, electric shock, fire, etc.
- Never attempt inappropriate disassembly or assembly of the product relating to basic construction, or to its performance or to functions. Doing so creates the risk of injury, electric shock, fire, etc.
- Do not splash water on the product. Splashing water on the product, or washing it or using it in water can cause malfunctions and create the risk of personal injury, electric shock, fire, etc.

 **WARNING**

- Do not use the actuator as a device for absorbing the shocks and vibrations of mechanical equipment. The actuator could be damaged, resulting in injury or in damage to mechanical equipment.
- Do not use the product in excess of its specification range. Using the product outside its specified range causes it to malfunction, stop functioning, and break. It could also lead to a significantly reduced service life.

- Design equipment, as well as safety circuits, so that people are not injured and equipment is not damaged if there is an emergency stop, power outage, or other system abnormality that stops the machinery.
- If using the product in the locations listed below, implement adequate shielding measures. Failure to implement these measures may lead to erratic operation that could cause equipment damage or personal injury.
 1. Locations subject to large electric current or magnetic fields
 2. Locations subject to noise due to static electricity, etc.
 3. Locations with the possibility of exposure to radiation
- Be sure to ground in accordance with special class D grounding work (ground resistance is 100 Ω or less). Current leakage could cause electric shock or erratic operation.
- Before installing products to the equipment, be sure to check that the mounting, wiring, and operation commands are correct. Using the product without checking could result in injury or equipment damage by coming in contact with moving parts.
- Before supplying electricity to the product and before starting operation, always conduct a safety check of the area where the equipment is operating. Unintentional supply of electricity creates the risk of electric shock or injury due to contact with moving parts.
- Do not touch terminals, switches, etc., while power is turned on. There is a risk of electric shock or abnormal operation.
- Do not allow cables and other cords to become damaged. Allowing cords to become damaged, bent excessively, stretched, coiled, placed under heavy objects, or pinched may result in current leakage or defective continuity, creating the risk of fire, electric shock, or malfunction.
- If abnormal noise occurs or vibrations are excessive, immediately stop operations. Continued use in this condition may result in abnormal operation or runaway operation due to product damage or destruction.
- Do not allow the product to be thrown into fire. The product could explode and/or release toxic gases.
- Do not climb on, step on, or place anything on the product. Doing so could result in personal injury from tripping over, knocking over, or dropping the product, the product could be damaged, and the damage may cause malfunction or runaway.
- Be sure to completely cut off the power before doing any work, such as maintenance inspections, repairs, or replacing parts, on the product.
- Use the product within the recommended loads and speed specifications.

 **Caution**

- Do not use the product in locations subject to direct sunlight (ultraviolet radiation), dust, salt, or iron powder, or environments that are very humid, or that contain organic solvents, phosphate-based hydraulic fluid, sulphur dioxide gas, chlorine gas, acids, etc. It could lead to early loss of some functions, a sudden degradation of performance, and a reduced operating life.
- Do not use the product in environments that contain corrosive gases, combustible gases, or flammable liquids, etc. It could lead to a decrease in strength due to rust, or to a risk of the motor igniting or exploding.
- Be sure to use the controller specified for the product. Using an unspecified one could damage the product or cause runaway.
- Install the actuator and controller where there is little dust or dirt. Installing them in locations where there are large amounts of dust and dirt could cause abnormal operation.
- Do not install in a location subject to extreme vibrations (4.9 m/s² [0.5 G] or more). The product could malfunction if exposed to extreme vibrations.
- When mounting the product, leave room for adequate working space around it. Failure to leave working space will make it more difficult to conduct daily inspections or maintenance, which could eventually lead to system shutdown or damage to the product.
- Do not bring any magnetic media or magnetic data within 1 m [3.280 ft] of the product. Doing so creates the risk of damage to data on the magnetic medium due to magnetism.
- Do not mar, scratch, or deform the drive components by climbing on, stepping on, or placing anything on the product. Doing so could result in operations stopping or performance falling due to the product being damaged or broken.
- When doing installation or adjustment work, clearly display work-in-progress signs so that the electric power supply is not turned on unintentionally. Unintentional supply of electricity creates the risk of injury due to electric shock or sudden operation of the actuator.
- Never conduct an insulation resistance test or dielectric strength test on the controller.
- Do not subject the ends of the cables to excessive force.
- Secure the cable connectors so they are not subject to any bending moment.

 **ATTENTION**

- Whenever considering use of this product in situations or environments not specifically noted in the catalog or in manuals, or in applications where safety is an important requirement such as in aircraft facilities, combustion equipment, leisure equipment, safety equipment, and other places where human life or assets may be greatly affected, take adequate safety precautions such as allowing plenty of margin for ratings and performance, or fail-safe measures. Contact Koganei regarding use in such applications.
- Isolate the operating components of machinery, such as with protective covers, so there is no direct contact with people.
- Do not configure controls so that workpieces fall if there is a power outage. Configure measures to prevent workpieces from falling in case the equipment has a power outage or emergency stop.
- Refer to the "Owner's Manual" while installing or wiring the product.
- Wear protective gloves, safety glasses, safety shoes, and other protective clothing as necessary to be safe when handling the product.
- Always conduct daily inspections and confirm that all requisite system functions are satisfied to prevent accidents from happening.
- When the product can no longer be used or is no longer necessary, dispose of it appropriately as industrial waste.
- For inquiries about the product, consult your nearest Koganei sales office or the Overseas Department. The addresses and telephone numbers are shown on the back cover of this catalog.

 **Other precautions**

- The following precautions must be observed.
 1. When using this product in a system, use only genuine Koganei parts or compatible parts (recommended parts). Use only genuine Koganei parts or compatible parts (recommended parts) to do maintenance or repairs. Use only specified procedures and methods.
 2. Never inappropriately disassemble or assemble the product as relates to its basic construction, or to its performance or functions.

Koganei cannot be held responsible for any problems that occur as a result of these safety precautions not being properly observed.

Warranty and disclaimer

1. Warranty period

The warranty period of Koganei products is one year from the date of delivery.

* Some products have a two-year warranty period. For details, contact the nearest Koganei sales office or Overseas Department.
2. Warranty scope and disclaimer
 - (1) If a failure attributable to Koganei is found in a product purchased from Koganei or an authorized retailer/dealer during the warranty period, Koganei will repair or replace it free of charge. Even if a product is still within the warranty period, its durability is determined by its operation cycles and other factors. Contact your nearest Koganei sales office or the Koganei overseas department for details.
 - (2) The Koganei product warranty covers that product alone. Consequently, Koganei is not responsible for any incidental damage (including costs incurred for the repair and replacement of the product) attributable to any failure of the Koganei product, decrease in function, or decrease in performance.
 - (3) Koganei is not responsible for any losses or for any damages to other machinery caused by breakdown, loss of function, or loss of performance of Koganei products.
 - (4) Koganei is not responsible for any losses due to use or storage of the product in a way that is outside of the product specifications prescribed in Koganei catalogs and instruction manuals, and/or due to actions that violate the mounting, installation, adjustment, maintenance or other safety precautions.
 - (5) Koganei is not responsible for any losses caused by breakdown of the product due to factors outside the responsibility of Koganei, including but not limited to fire, natural disaster, the actions of third parties, and intentional actions or errors by the purchaser.



General precautions

Lubrication

Apply CGL grease (manufactured by Nippon Thompson Co., Ltd.) to the sliding parts of the track rails approximately every 6 months or 3 million operations.

Environment

1. Avoid using the actuator, controller, and teaching box in very dusty locations or locations where they could be splashed with water or oil.
2. Avoid use in locations subject to corrosive gases, such as sulfuric acid or hydrochloric acid.
3. Even though stainless steel is used in the materials in the main unit and table, rusting may occur, depending on the operating environment. Apply anti-rust oil periodically. Touching the main unit or table with bare hands could cause rust, due to the sweat and salt. We recommend using gloves.
4. Do not use in extremely dry conditions.
5. Avoid use in locations subject to extreme vibration or shock.
6. For the standard specifications, the sliding ball-screw rod is exposed from the slit in the top of the main unit when the table is moved to the OUT side. The user should take measures if there is a risk of foreign matter getting inside. Or, select specifications that can withstand foreign matter.

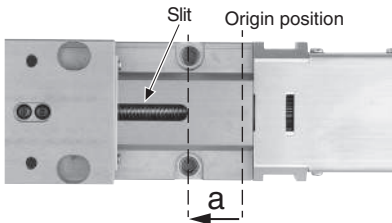

Model	a
EW2G10□	10
EW2G12□	19
EW2G16□	17

During use

1. The main unit and table are martensitic stainless steel, so they will become magnetized if magnets or magnetized things are attached to them.
2. Use the pressing mode to press workpieces or to use an external stopper (stroke adjustment mechanism) for stopping. Touching the workpiece or stopper when in positioning mode, could cause an error or damage to the actuator.
3. This product does not have a brake. The table will not drop under its own weight if the maximum payload (perpendicular) specifications are exceeded, but the position of the table could be shifted if subjected to vibrations or shocks. We recommend protections at the stroke end when the table is pressed (C, O, or U mode) and subject to vibrations or shocks.

Stroke direction

EW2G□, EW2G□C

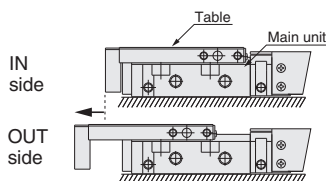

EW2G□R^{Note}

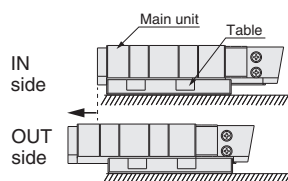

Note: For fixed table types (EW2G□R), tables are the mounting surface for the product.



Installation and stroke adjustment

Installation

1. You can mount the product in any position, but the flatness of the mounting surface of the mating part, such as the workpiece and base, must be 0.02 mm [0.001 in.] or less. Poor flatness could result in a loose guide or increased rolling resistance, or adversely affect the service life.
2. Avoid scratching or denting the mounting surface of the actuator, as doing so could adversely affect the flatness.
3. When mounting a workpiece or bracket, be careful not to apply strong shock or excessive moment to the guide. When mounting a workpiece or bracket on the table, secure it while holding the table, and when mounting it on the main unit, secure it while holding the main unit. Applying strong shock or excessive moment to the guide will lead to poor guide accuracy.
4. Make sure that the mounting bolts have sufficient strength. When mounting a workpiece or bracket, tighten the bolts to an appropriate torque within the allowable range.
5. If there is a risk of bolts loosening due to shocks or vibrations, consider taking measures to prevent them from loosening.
6. For the positioning pin hole, use the clearance-fit stepped pin (option). Press-fitting the pin could cause damage to the guide due to an excessive load. The pin hole on the table is a through hole. Using a pin other than the stepped pin could cause a contact between the pin and main unit, resulting in a failure.
7. Moving the table of a high-torque type manually may be impossible. To move the table, use the hexagonal hole for table operations or use the dial for table operations.

Mounting a workpiece

EW2G□, EW2G□C

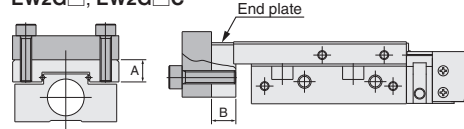

EW2G□R

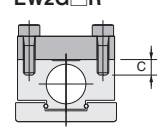

Model	Bolt used	Maximum tightening torque N·m [in·lbf]	Maximum thread depth A mm [in.]	Maximum thread depth B mm [in.]	Maximum thread depth C mm [in.]
EW2G10□	M3×0.5	0.63 [5.576]	5 [0.197]	5 [0.197]	4 [0.157]
EW2G12□	M4×0.7	1.5 [13.277]	7 [0.276]	6 [0.236]	7 [0.276]
EW2G16□	M4×0.7	1.5 [13.277]	8.5 [0.335]	7 [0.276]	9.5 [0.374]



Make sure that the workpiece mounting bolts are equal to or shorter than the maximum thread depth. A bolt longer than the maximum thread depth could reach and damage the main unit.

EW2G□R does not have an end plate.

Installing the product

EW2G□, EW2G□C

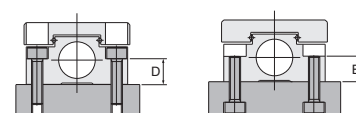

EW2G□R^{Note}

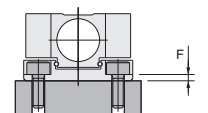

Model	Bolt used	Maximum tightening torque N·m [in·lbf]	D mm [in.]	F mm [in.]
EW2G10□	M3×0.5	1.14 [10.090]	7 [0.276]	1.5 [0.059]
EW2G12□	M4×0.7	2.7 [23.898]	6 [0.236]	3.5 [0.138]
EW2G16□	M4×0.7	2.7 [23.898]	9 [0.354]	6 [0.236]

Model	Bolt used	Maximum tightening torque N·m [in·lbf]	E mm [in.]
EW2G10□	M4×0.7	2.7 [23.898]	7 [0.276]
EW2G12□	M5×0.8	5.4 [47.795]	6 [0.236]
EW2G16□	M5×0.8	5.4 [47.795]	9 [0.354]

Note: EW2G□R is mounted by direct mounting only.

Handling instructions and precautions

Stroke adjuster set

When the stroke adjustment mechanism is selected, the stroke adjuster set is provided. When mounting the stroke adjuster, secure it appropriately with the following tightening torques.

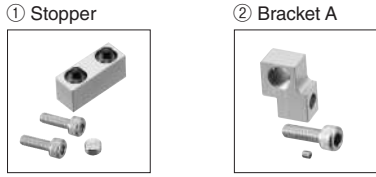

Tightening torque for stroke adjuster

Model	① Stopper		② Bracket A	
	Bolt used	Tightening torque N·m [in·lbf]	Bolt used	Tightening torque N·m [in·lbf]
EW2G10□	M2.5×0.45	0.65 [5.753]	M3×0.5	0.63 [5.576]
EW2G12□	M3×0.5	1.14 [10.090]	M4×0.7	1.5 [13.277]
EW2G16□	M4×0.7	2.0 [17.702]	M5×0.8	3.0 [26.553]

Accuracy

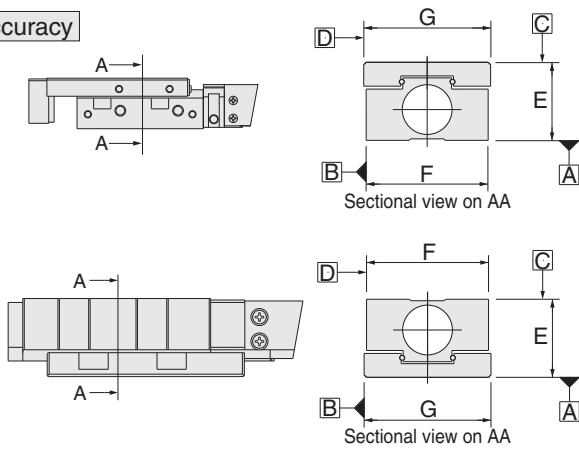

Mounting parallelism(face C relative to face A, face D relative to face B) mm [in.]

Model	Stroke							
	10	20	30	40	50	60	80	100
EW2G10□	0.03 [0.001]	-	0.03 [0.001]	-	0.03 [0.001]	-	-	-
EW2G12□	-	0.03 [0.001]	-	0.03 [0.001]	-	0.03 [0.001]	0.05 [0.002]	-
EW2G16□	-	0.03 [0.001]	-	0.03 [0.001]	-	0.03 [0.001]	-	0.06 [0.002]

Traveling parallelism(face C relative to face A, face D relative to face B) mm [in.]

Model	Stroke							
	10	20	30	40	50	60	80	100
EW2G10□	0.005 [0.0001]	-	0.005 [0.0001]	-	0.006 [0.0002]	-	-	-
EW2G12□	-	0.005 [0.0001]	-	0.005 [0.0001]	-	0.007 [0.0002]	0.012 [0.0004]	-
EW2G16□	-	0.005 [0.0001]	-	0.005 [0.0001]	-	0.007 [0.0002]	-	0.018 [0.001]

mm [in.]

Motor size	10·12·16
Dimensional tolerance for E	±0.05 [0.002]
Dimensional tolerance for F	±0.05 [0.002]
Dimensional tolerance for G	±0.05 [0.002]

● Guide center mm [in.]

Model	Stroke	X	Y
EW2G10□	10	31.7 [1.248]	27.3 [1.075]
	30	51.7 [2.035]	47.3 [1.862]
	50	76.7 [3.020]	72.3 [2.846]
EW2G12□	20	48 [1.890]	42 [1.654]
	40	68 [2.677]	62 [2.441]
	60	88 [3.465]	82 [3.228]
EW2G16□	80	108 [4.252]	102 [4.016]
	20	50 [1.969]	43 [1.693]
	40	70 [2.756]	63 [2.480]
	60	90 [3.543]	83 [3.268]
	100	140 [5.512]	133 [5.236]

Allowable moment

The Low Profile Electric Slider can be used by applying a load directly to it, but be careful that the load or moment does not exceed the value given in the table below. Also, be aware that if the workpiece is brought into contact with a point offset from the guide in the middle of the stroke, a large moment is generated by the thrust of the Low Profile Electric Slider.

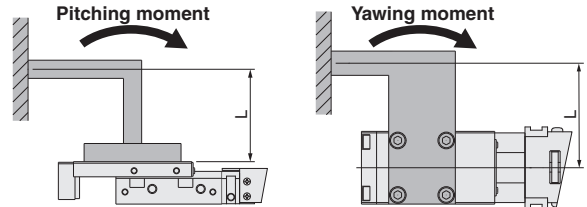

● Allowable moment N·m [in·lbf]

Model	Mp	My	Mr
EW2G10□	0.28 [2.478]	0.34 [3.009]	0.38 [3.363]
EW2G12□	1.5 [13.277]	1.7 [15.047]	2.6 [23.013]
EW2G16□	2.1 [18.587]	2.5 [22.128]	4.3 [38.059]

Remarks: For the allowable moment, apply a safety factor of 10 to the calculated value for the guide. However, this calculated value is not a guaranteed value.

● Calculated values for the guide (reference values)

Model	Basic dynamic load rating C (N [lbf])	Basic static load rating Co (N [lbf])	Static rated moment (N·m [in·lbf])		
			Mp	My	Mr
EW2G10□	417 [93.742]	734 [165.0]	2.8 [24.783]	3.4 [30.093]	3.8 [33.634]
EW2G12□	1710 [384.4]	2690 [604.7]	14.5 [128.3]	17.2 [152.2]	25.6 [226.6]
EW2G16□	2390 [537.3]	3440 [773.3]	20.7 [183.2]	24.7 [218.6]	43.3 [383.2]

Remarks: Common to all strokes. They are not guaranteed values.

● Moment direction, guide center X

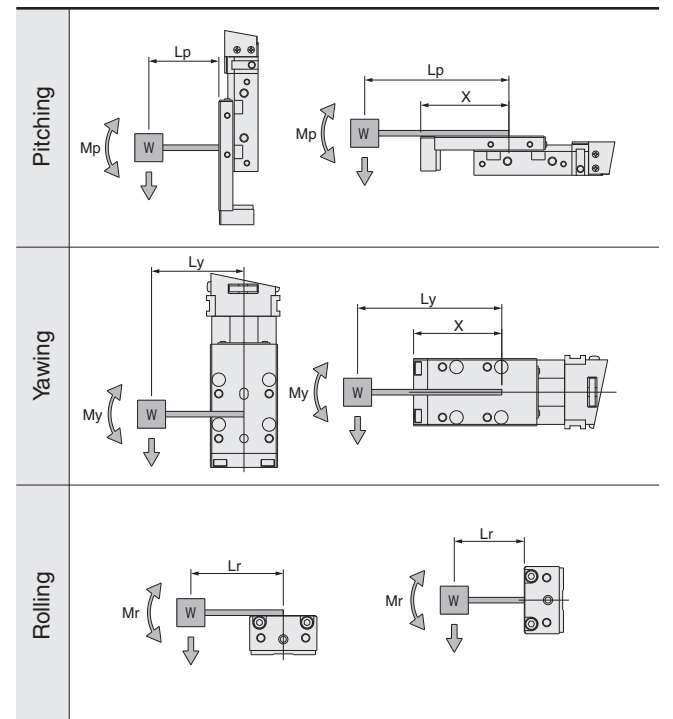

(Guide center Y for EW2G□R)

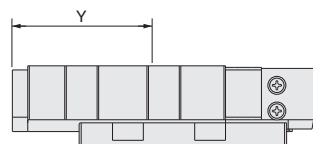

Note: The moment center must be determined based on the guide center shown in the figure.

Handling instructions and precautions

Displacement angle of the table in relation to bending moment

(Reference value)

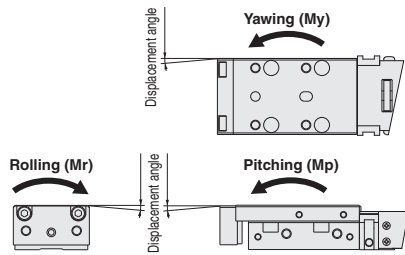

EW2G10 (Motor size 10)

Pitching (Mp)

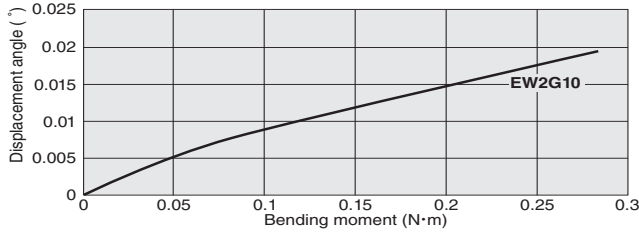

Yawing (My)

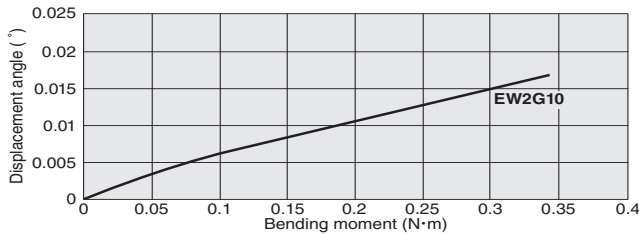

Rolling (Mr)

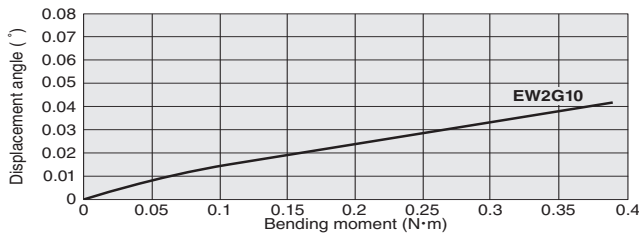

EW2G12, EW2G16 (Motor size 12, 16)

Pitching (Mp)

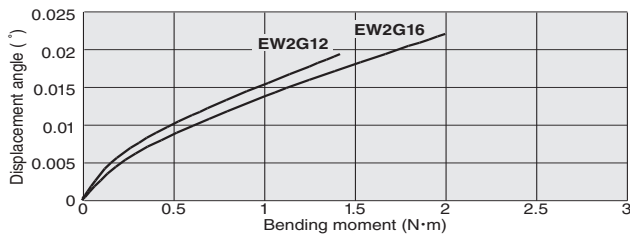

Yawing (My)

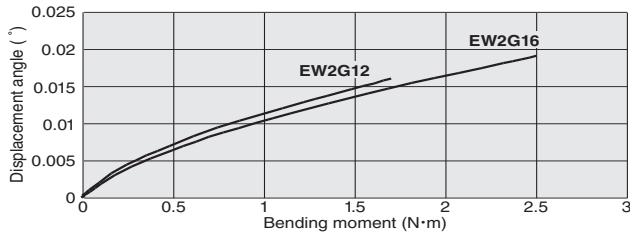

Rolling (Mr)

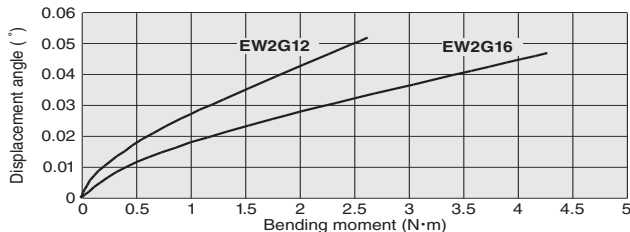

Other precautions

1. Be sure to read the instruction manual before use.
2. Use electric actuators and controllers in combinations according to the correspondence tables on page 35.
3. Install the controller so there is adequate space around it (20 mm [0.787 in.] or more) with good ventilation.

4. For the ground terminal of the controller, use the F.G. wire of the power cable.

When EW2C-H-CC or EW2C-H-CCD (CC-Link type) is grounded, it is recommended that the length of the F.G. wire of the power cable be 250 mm [9.843 in.] or less. If it is longer than 250 mm [9.843 in.], communication may be affected by external noise.

For conformity to the CE marking standards, the following measures are required, for example, when connecting the controller to peripheral devices.

1. Install a clamp filter (two turns) to the power cable.
2. Install a clamp filter to the controller side of the connecting cable.
 - EW2C-H-NP, EW2C-H-PN: 1 (2 turns)
 - EW2C-H-CC: 3 pcs. (2 turns each)
 - EW2C-H-CCD: 4 pcs. (2 turns each)
3. Do not coil a connecting cable or bundle multiple cables.
4. Use a CC-Link cable that is less than 30 m [98.400 ft] long.
5. To operate the controller with the teaching box (EW2TB) connected, install a clamp filter (two turns) to the teaching box cable.

5. If reciprocating motion is repeated over a short distance, the grease film could break.

It is recommended to repeat reciprocating motion five times or so with full stroke every 5,000 to 10,000 reciprocations so as to recover the grease film.

6. Since this product uses a finite track guide, if reciprocating motion is repeated over a stroke shorter than that required for operation, the steel balls could get out of alignment due to a microslip, resulting in looseness. When selecting the model, select one with a stroke close to that in actual use and ensure that the stroke is equal to or larger than that required for operation.

We also recommend doing full strokes periodically or after a certain number of operations to prevent the steel balls from getting out of alignment.

Model	Stroke range [mm [in.]]
EW2G10□-10	0 or more
EW2G10□-30	15 [0.591] or more
EW2G10□-50	30 [1.181] or more
EW2G12□-20	0 or more
EW2G12□-40	20 [0.787] or more
EW2G12□-60	40 [1.575] or more
EW2G12□-80	60 [2.362] or more
EW2G16□-20	0 or more
EW2G16□-40	20 [0.787] or more
EW2G16□-60	40 [1.575] or more
EW2G16□-100	65 [2.559] or more

7. The maximum speed may not be reached if the distance moved is short.

※EW2G□R (fixed table type) uses guides with the same performance. Contact us about the displacement angle in relation to the bending moment of EW2G□R.

Low Profile Electric Slider



Specifications

● Basic specifications of product

Item	Model	EW2G10□H	EW2G10□S	EW2G12□H	EW2G12□S	EW2G16□H	EW2G16□S	
Motor size	mm [in.]	φ10 [0.394]		φ12 [0.472]		φ16 [0.630]		
Type		High-speed type	High-torque type	High-speed type	High-torque type	High-speed type	High-torque type	
Lead	[mm [in.]]	4 [0.157]	2 [0.079]	4 [0.157]	2 [0.079]	4 [0.157]	2 [0.079]	
Motor		Brushless motor						
Maximum thrust ^{Note 1}	N [lbf]	10 [2.248]	20 [4.496]	20 [4.496]	40 [8.992]	30 [6.744]	60 [13.488]	
Maximum payload (horizontal) ^{Note 2}	kg [lb]	0.6 [1.323] (0.5 [1.103])	1 [2.205] (0.9 [1.985])	0.8 [1.764] (0.65 [1.433])	1.4 [3.087] (1.25 [2.756])	1.2 [2.646] (0.9 [1.985])	2 [4.410] (1.7 [3.749])	
Maximum payload (vertical) ^{Note 2}	kg [lb]	0.3 [0.662] (0.2 [0.441])	0.5 [1.103] (0.4 [0.882])	0.4 [0.882] (0.25 [0.551])	0.7 [1.544] (0.55 [1.213])	0.6 [1.323] (0.3 [0.662])	1 [2.205] (0.7 [1.544])	
Maximum speed (positioning mode)	mm/s [in./sec]	100 [3.937]	50 [1.969]	100 [3.937]	50 [1.969]	100 [3.937]	50 [1.969]	
Maximum speed (pushing mode)	mm/s [in./sec]	20 [0.787]	10 [0.394]	20 [0.787]	10 [0.394]	20 [0.787]	10 [0.394]	
Minimum speed	mm/s [in./sec]	10 [0.394]	5 [0.197]	10 [0.394]	5 [0.197]	10 [0.394]	5 [0.197]	
Repeatability of positioning accuracy (positioning mode and intermediate stop) ^{Note 6}	mm [in.]	±0.08 [0.003]	±0.06 [0.002]	±0.08 [0.003]	±0.06 [0.002]	±0.08 [0.003]	±0.06 [0.002]	
Repeatability of positioning accuracy ^{Note 3} (when in pushing mode and an external stopper is used)	mm [in.]	±0.005 [0.0001]						
Stroke ^{Note 4}	mm [in.]	10 [0.394], 30 [1.181], 50 [1.969]		20 [0.787], 40 [1.575], 60 [2.362], 80 [3.150]		20 [0.787], 40 [1.575], 60 [2.362], 100 [3.937]		
Mass (w/o option, for each stroke)	kg [lb]	0.15 [0.331], 0.2 [0.441], 0.3 [0.662]		0.3 [0.662], 0.35 [0.772], 0.42 [0.926], 0.5 [1.103]		0.45 [0.992], 0.6 [1.323], 0.7 [1.544], 0.95 [2.095]		
Stroke adjustment range (when an external stopper is used)	mm [in.]	OUT side: -9 to 0 [-0.354 to 0] IN side: -10 to 0 [-0.394 to 0]		OUT side: -8 to 0 [-0.315 to 0] IN side: -8 to 0 [-0.315 to 0]		OUT side: -7 to 0 [-0.276 to 0] IN side: -5 to 0 [-0.197 to 0]		
Operating temperature range	°C [°F]	5 to 40 [41 to 104]						
Static rated moment ^{Note 5}	Mp	N·m [in·lbf]	2.8 [24.783]		14.5 [128.3]		20.7 [183.2]	
	My	N·m [in·lbf]	3.4 [30.093]		17.2 [152.2]		24.7 [218.6]	
	Mr	N·m [in·lbf]	3.8 [33.634]		25.6 [226.6]		43.3 [383.2]	
Applicable controller		EW2C-H-NP, EW2C-H-PN, EW2C-H-CC, EW2C-H-CCD						

Note 1: For details on the pushing force, see the graphs on P.36.

2: The values in parentheses indicate the values for the fixed table type.

3: To stop the movement with an external stopper, always use pushing mode.

Note 4: Use the product within the stroke range.

5: For details on the moment, refer to P.7.

6: When operating conditions are the same

Order codes

● Product model (standard type)

EW2G □ □ - □ - □ - □ - □ - □ - □ - □ - □ - □

Elewave
Low Profile
Electric Slider

Size (Motor size)
10: φ10 [0.394]
12: φ12 [0.472]
16: φ16 [0.630]

Type
S: High torque
H: High speed

Stroke
Note: See the table on the right about size and stroke combinations.

Direction of cable
Blank: Straight
1: Pull out in direction 1
2: Pull out in direction 2
3: Pull out in direction 3
4: Pull out in direction 4

Positioning pin (provided)
Blank: Not equipped
P1: 1 pc.
P2: 2 pc.
P3: 3 pc.
P4: 4 pc.

Vertical bracket (provided)
Blank: Not equipped
BK1: Bracket 1 (2 pc. provided)
BK2: Bracket 2 (1 pc. provided)
BK3: Bracket 3 (1 pc. provided)

DIN rail mounting plate
Blank: Not equipped
DP: With (not selectable if there is no controller)

Controller type
Blank: No controller
NP: Point input type (NPN model)
PN: Point input type (PNP model)
CC: CC-Link remote I/O type
CCD: CC-Link remote device type

Cable length (for connection)
Blank: Not equipped
3L: 3 m [9.840 ft]
5L: 5 m [16.400 ft]

Stroke adjustment mechanism (provided)
Blank: Not equipped
MS2: Metal stoppers on both sides (2 pc. provided)
MSF: Metal stopper on OUT side (1 pc. provided)
MSR: Metal stopper on IN side (1 pc. provided)

*Direction of cable

Size and stroke combinations

Size	10	12	16
10	●	-	-
20	-	●	●
30	●	-	-
40	-	●	●
50	●	-	-
60	-	●	●
80	-	●	-
100	-	-	●

Order codes

● Product model (Measure against foreign objects C: Cover specifications)

EW2G **C** - - - - - - - - - -

Elewave Low Profile Electric Slider

Size (Motor size)
10: φ10 [0.394]
12: φ12 [0.472]
16: φ16 [0.630]

Measure against foreign objects
C: Cover type

Stroke adjustment mechanism (provided)
Blank: Not equipped
MS2: Metal stoppers on both sides (2 pc. provided)
MSF: Metal stopper on OUT side (1 pc. provided)
MSR: Metal stopper on IN side (1 pc. provided)

Type
S: High torque
H: High speed

Stroke
 Note: See the table on the right about size and stroke combinations.

Direction of cable
Blank: Straight
1: Pull out in direction 1
2: Pull out in direction 2
3: Pull out in direction 3

*Direction of cable

Positioning pin (provided)
Blank: Not equipped
P1: 1 pc.
P2: 2 pc.
P3: 3 pc.
P4: 4 pc.

Vertical bracket (provided)
Blank: Not equipped
BK1: Bracket 1 (2 pc. provided)
BK2: Bracket 2 (1 pc. provided)
BK3: Bracket 3 (1 pc. provided)

DIN rail mounting plate
Blank: Not equipped
DP: With (not selectable if there is no controller)

Controller type
Blank: No controller
NP: Point input type (NPN model)
PN: Point input type (PNP model)
CC: CC-Link remote I/O type
CCD: CC-Link remote device type

Cable length (for connection)
Blank: Not equipped
3L: 3 m [9.840 ft]
5L: 5 m [16.400 ft]

Size	10	12	16
10	●	-	-
20	-	●	-
30	●	-	-
40	-	●	●
50	●	-	-
60	-	●	●
80	-	●	-
100	-	-	●

● Product model (Measure against foreign objects R: Fixed table type)

EW2G **R** - - - - - - - - - -

Elewave Low Profile Electric Slider

Size (Motor size)
10: φ10 [0.394]
12: φ12 [0.472]
16: φ16 [0.630]

Measure against foreign objects
R: Fixed table type

Stroke adjustment mechanism (provided)
Blank: Not equipped
MS2: Metal stoppers on both sides (2 pc. provided)
MSF: Metal stopper on OUT side (1 pc. provided)
MSR: Metal stopper on IN side (1 pc. provided)

Type
S: High torque
H: High speed

Stroke
 Note: See the table on the right about size and stroke combinations.

Direction of cable
Blank: Straight
1: Pull out in direction 1
2: Pull out in direction 2
3: Pull out in direction 3

*Direction of cable

Positioning pin (provided)
Blank: Not equipped
P1: 1 pc.
P2: 2 pc.
P3: 3 pc.
P4: 4 pc.

Vertical bracket (provided)
Blank: Not equipped
BK1: Bracket 1 (2 pc. provided)
BK2: Bracket 2 (1 pc. provided)
BK3: Bracket 3 (1 pc. provided)

DIN rail mounting plate
Blank: Not equipped
DP: With (not selectable if there is no controller)

Controller type
Blank: No controller
NP: Point input type (NPN model)
PN: Point input type (PNP model)
CC: CC-Link remote I/O type
CCD: CC-Link remote device type

Cable length (for connection)
Blank: Not equipped
3L: 3 m [9.840 ft]
5L: 5 m [16.400 ft]

Size	10	12	16
10	●	-	-
20	-	●	-
30	●	-	-
40	-	●	●
50	●	-	-
60	-	●	●
80	-	●	-
100	-	-	●

Additional parts

● Controller

Point input type

EW2C - H - - - -

DIN rail mounting plate
Blank: w/o mounting plate
DP: w/ mounting plate

Controller type
NP: Point input type (NPN model)
PN: Point input type (PNP model)

CC-Link type

EW2C - H - - - -

DIN rail mounting plate
Blank: w/o mounting plate
DP: w/ mounting plate

Controller type
CC: CC-Link remote I/O type
CCD: CC-Link remote device type

*For controller specifications, refer to pages 28 and 29.

● Accessories: Power cable, I/O cable



● Accessories: Power cable, terminating resistor, connector for CC-Link

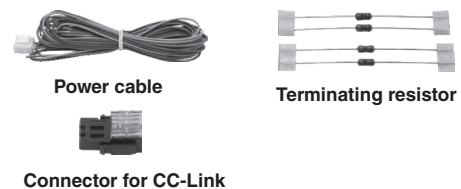

Additional parts

● Cable

EW2K



Length (type P, I cannot be selected)

- Blank: Not specified
- 008L: 80 mm [3.150 in.]
- 015L: 150 mm [5.906 in.]
- 025L: 250 mm [9.843 in.]
- 1L: 1 m [3.280 ft]
- 3L: 3 m [9.840 ft]
- 5L: 5 m [16.400 ft]

Type

- A : For connection
- P : For power supply
- I : For I/O
- D : For daisy chain (for RS485 communication)
- N : For communication (for RS485 communication)
- BA: Connecting cable (loose wires), for main unit
- BB: Connecting cable (loose wires), for controller

* For automatic hand changer (MJC) wiring
Note: Connecting cable (A, BA, BB) of robot cable.

Table of cable types and lengths

Length Type	008L	015L	025L	1L	3L	5L	Remarks
A	-	-	-	-	○	○	For connection
P	-	-	-	-	-	-	For power supply
I	-	-	-	-	-	-	For I/O
D	○	-	-	○	○	-	For daisy chain (for RS485 communication)
N	-	-	-	○	○	-	For communications (for RS485 communication)
BA	-	○	○	-	-	-	Main unit/loose wires specifications
BB	-	-	-	-	-	○	Controller/loose wires specifications



EW2KA: For connection



EW2KP: For power supply



EW2KI: For I/O



EW2KD: For daisy chain (for RS485 communication)



EW2KBA: Connecting cable (loose wires), for main unit



EW2KN: For communication (for RS485 communication)



EW2KBB: Connecting cable (loose wires), for controller

● Communications cable (USB-RS485 converter)

IBM2A - H1



Blank: w/ USB cable
N: w/o USB cable

● Terminating resistor (for RS485 communications)

EW2FR



(for CC-Link)

EW2FC



● CC-Link connector

EW2CC

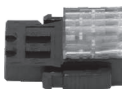

● CC-Link branch connector

EW2CY



● Teaching box

EW2TB

*For specifications, refer to page 26.



● DIN rail mounting plate

EW2DP



● Positioning pin (1 pc)

EW2P



Size
3: $\phi 3$ [0.118] (for EW2G10□)
4: $\phi 4$ [0.157] (for EW2G12□, EW2G16□)

EW2P-3

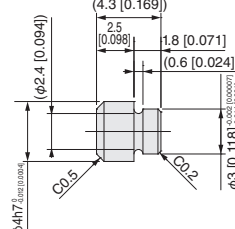

EW2P-4

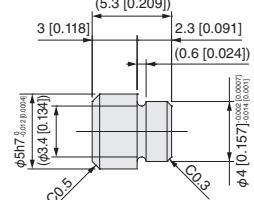

Additional parts

● Vertical bracket

EW2G-BK □ - □ - □

Bracket types

- 1: Bracket 1 (2 pc. provided)
- 2: Bracket 2 (1 pc. provided)
- 3: Bracket 3 (1 pc. provided)

Size (motor size)

- 10: $\phi 10$ [0.394]
- 12: $\phi 12$ [0.472]
- 16: $\phi 16$ [0.630]

Suitable stroke

(Note: Selection not required for BK1)

- 10: 10 mm [0.394 in.]
- 20: 20 mm [0.787 in.]
- 30: 30 mm [1.181 in.]
- 40: 40 mm [1.575 in.]
- 50: 50 mm [1.969 in.]
- 60: 60 mm [2.362 in.]
- 80: 80 mm [3.150 in.]
- 100: 100 mm [3.937 in.]

Note: See the table on the right about size and stroke combinations.

Size and stroke combinations

Stroke	Size	10	12	16
Stroke	10	●	-	-
	20	-	-	●
	30	●	-	-
	40	-	●	●
	50	●	-	-
	60	-	-	●
	80	-	●	-
	100	-	-	●



Bracket 1

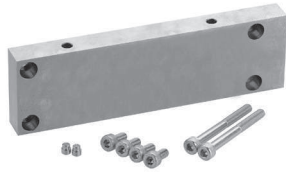

Bracket 2

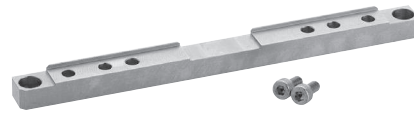

Bracket 3

● Stroke adjuster set

EW2G-MS □ - □ - □

Stroke adjuster

- S: Stopper set
- B: Bracket set

Size (motor size)

- 10: $\phi 10$ [0.394]
- 12: $\phi 12$ [0.472]
- 16: $\phi 16$ [0.630]

Stopper size

Note: Selection not required for MSB (bracket set)

- S: Small
- L: Large

Note: See the table on the right about stopper sizes.

Stopper size correspondence table

Stroke	Size	10	12	16
Stroke	10	S	-	-
	20	-	S	S
	30	S	-	-
	40	-	S	S
	50	L	-	-
	60	-	S	S
	80	-	S	-
	100	-	-	L



Stopper set



Bracket set
(with metal stopper)

EW2G10 (standard type)

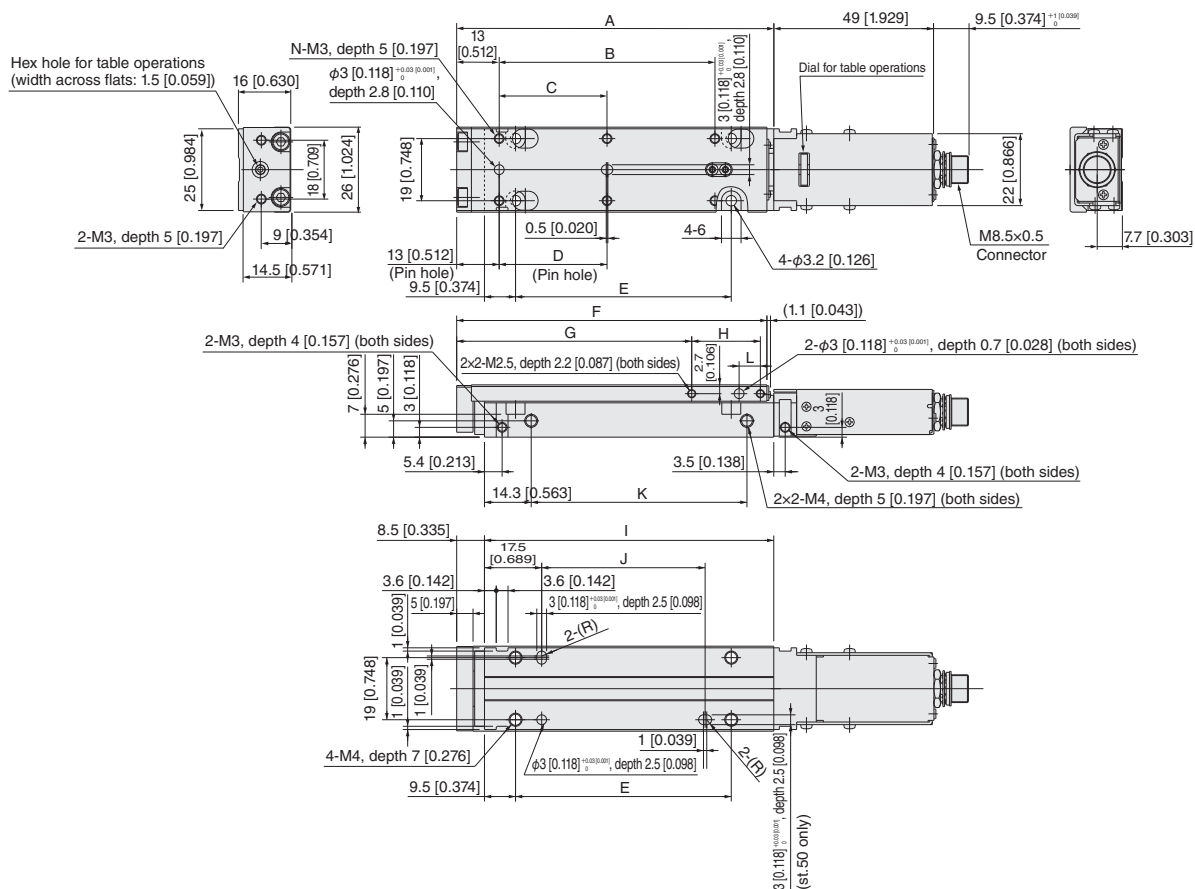

Stroke	A	B	C	D	E	F	G	H	I	J	K	L	N
10	47 [1.850]	-	16 [0.630]	10 [0.394]	16 [0.630]	44.9 [1.768]	31.9 [1.256]	11 [0.433]	38.5 [1.516]	-	16 [0.630]	6.5 [0.256]	4 [0.157]
30	67 [2.638]	-	36 [1.417]	30 [1.181]	36 [1.417]	64.9 [2.555]	51.9 [2.043]	11 [0.433]	58.5 [2.303]	-	36 [1.417]	6.5 [0.256]	4 [0.157]
50	97 [3.819]	66 [2.598]	33 [1.299]	33 [1.299]	66 [2.598]	94.9 [3.736]	71.9 [2.831]	21 [0.827]	88.5 [3.484]	50 [1.969]	66 [2.598]	7 [0.276]	6 [0.236]

Cable direction: For -1, -2, -3, or -4 (view from arrow R)

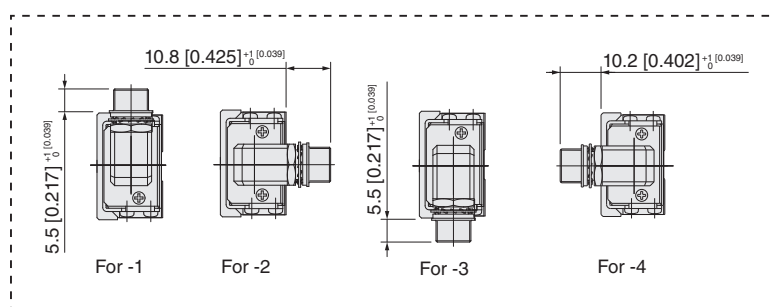
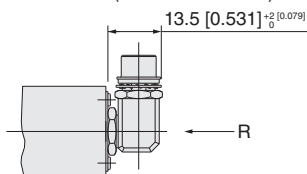

EW2G10C (Measure against foreign objects: Cover type)

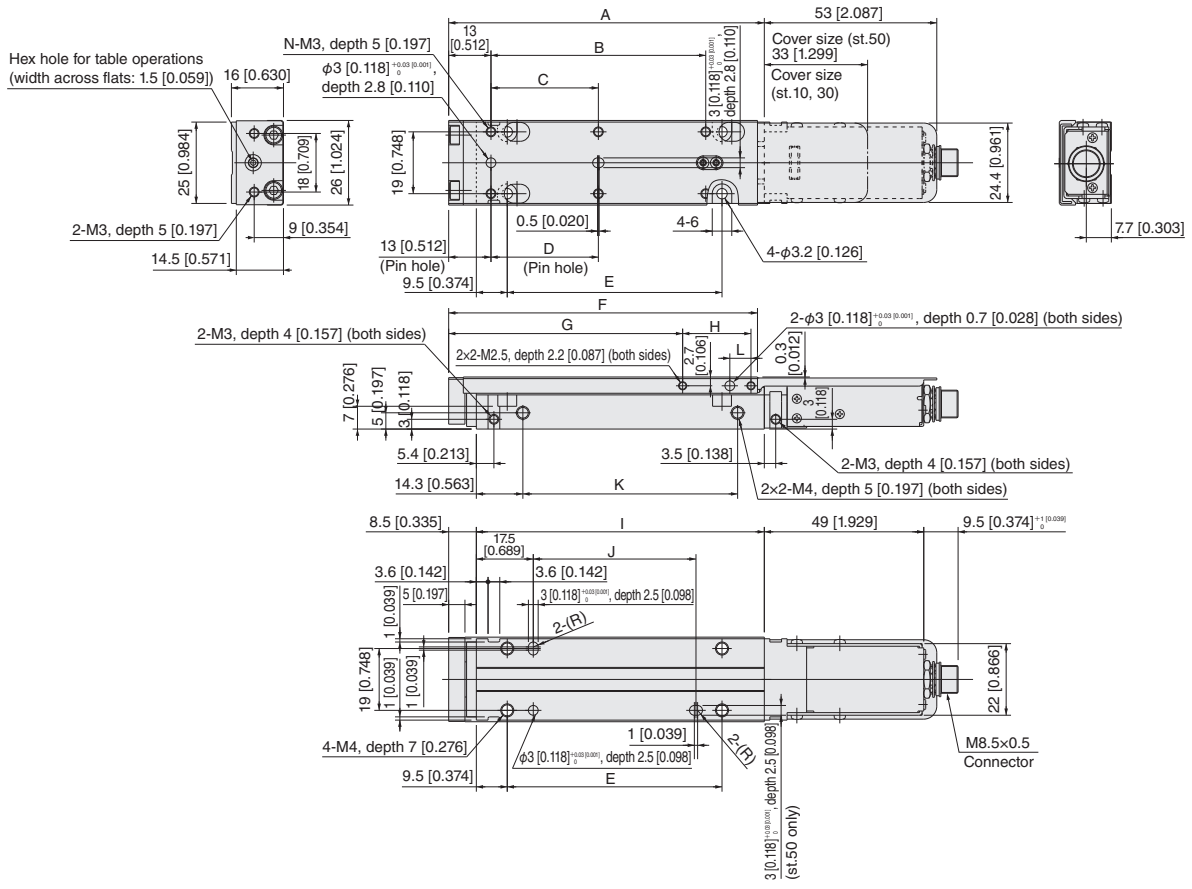

Stroke	A	B	C	D	E	F	G	H	I	J	K	L	N
10	47 [1.850]	-	16 [0.630]	10 [0.394]	16 [0.630]	44.9 [1.768]	31.9 [1.256]	11 [0.433]	38.5 [1.516]	-	16 [0.630]	6.5 [0.256]	4 [0.157]
30	67 [2.638]	-	36 [1.417]	30 [1.181]	36 [1.417]	64.9 [2.555]	51.9 [2.043]	11 [0.433]	58.5 [2.303]	-	36 [1.417]	6.5 [0.256]	4 [0.157]
50	97 [3.819]	66 [2.598]	33 [1.299]	33 [1.299]	66 [2.598]	94.9 [3.736]	71.9 [2.831]	21 [0.827]	88.5 [3.484]	50 [1.969]	66 [2.598]	7 [0.276]	6 [0.236]

Cable direction: For -1, -2, or -3
(view from arrow R)

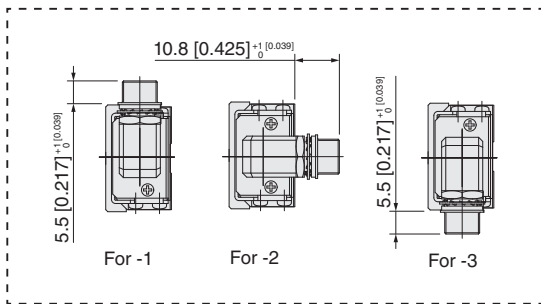
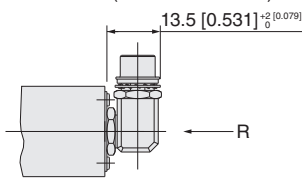

EW2G10R (Measure against foreign objects: Fixed table type)

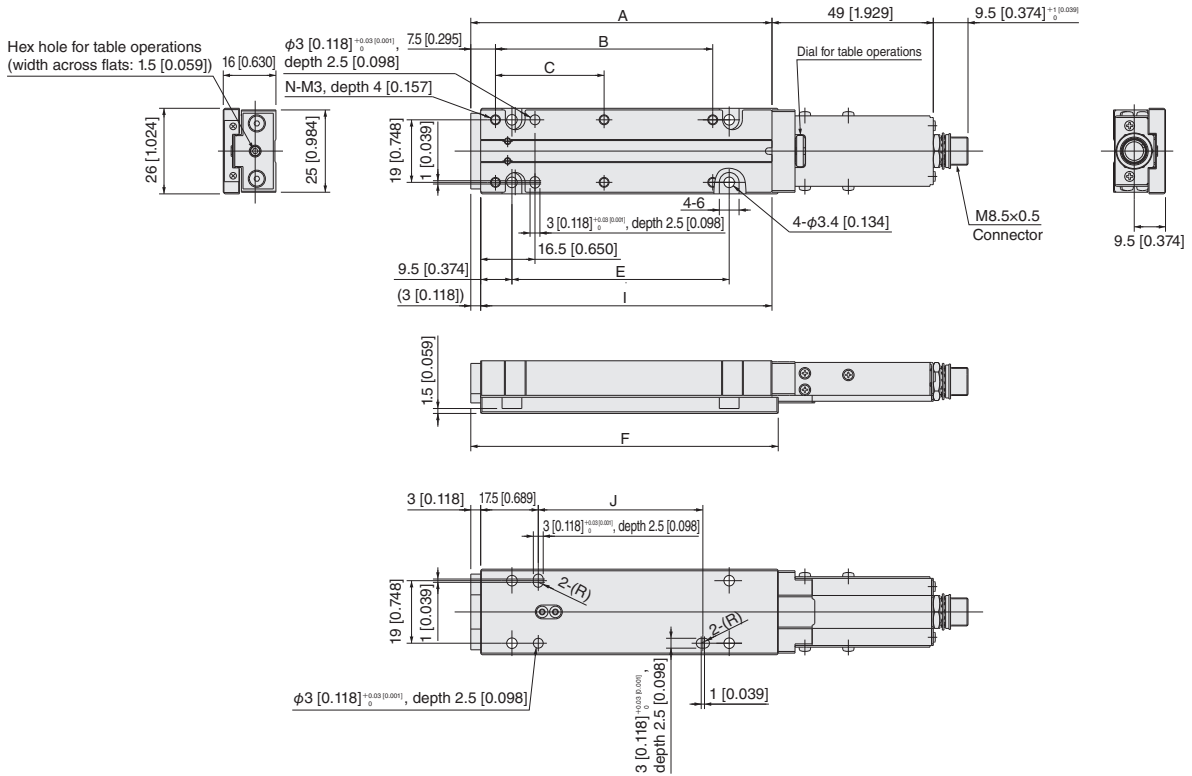

Stroke	A	B	C	E	F	I	J	N
10	41.5 [1.634]	-	16 [0.630]	16 [0.630]	43.4 [1.709]	38.5 [1.516]	-	4 [0.157]
30	61.5 [2.421]	-	36 [1.417]	36 [1.417]	63.4 [2.496]	58.5 [2.303]	-	4 [0.157]
50	91.5 [3.602]	66 [2.598]	33 [1.299]	66 [2.598]	93.4 [3.677]	88.5 [3.484]	50 [1.969]	6 [0.236]

● Dimensions with the connecting cable mounted and dimensions with the cable bent (reference values)

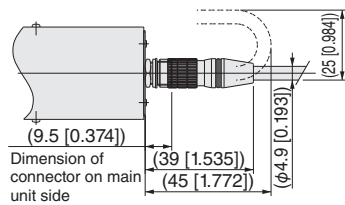

Note) As is the case with different cable directions, the dimensions with the connecting cable mounted are longer than those with the connecting cable not mounted by +30 mm [1.181 in.] or so.

EW2G10 - **Stroke** - **MS** (w/ stroke adjustment mechanism and bracket set)

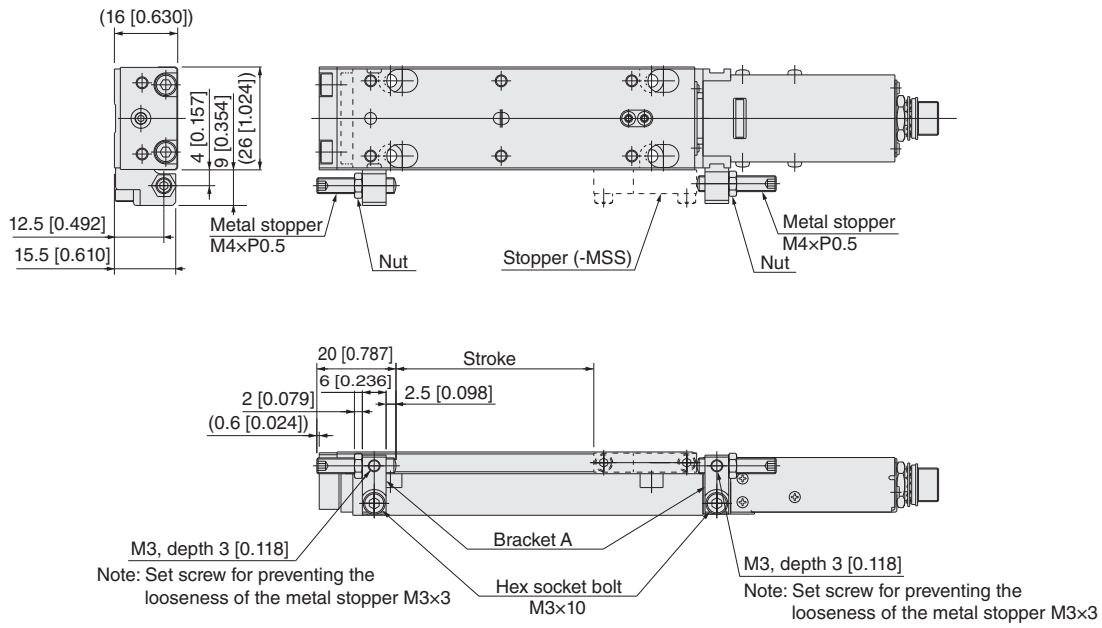

EW2G10 - **Stroke** - **MS** (w/ stroke adjustment mechanism and stopper set)

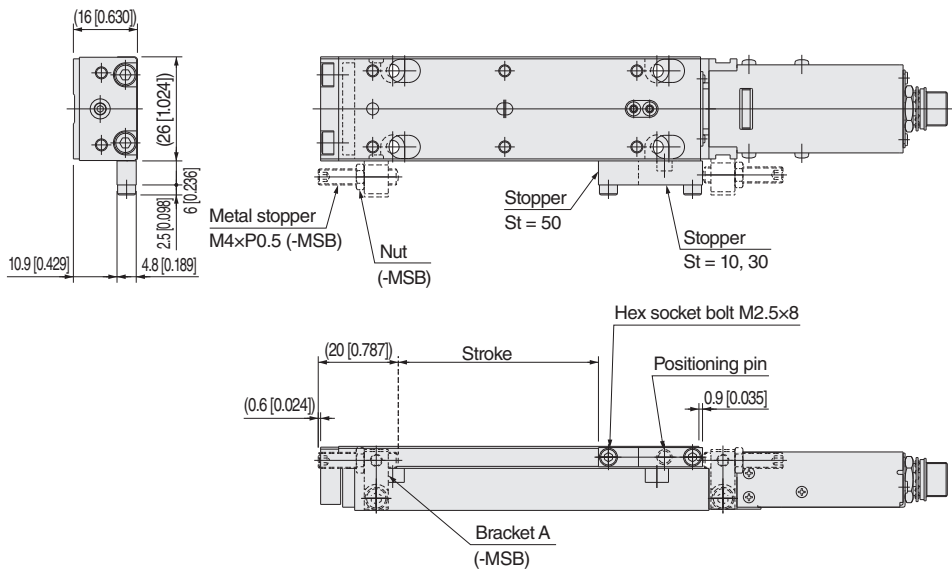

Thin Electric Slider Dimensions (mm [in.])

Vertical bracket (additional parts)

●EW2G-BK1-10

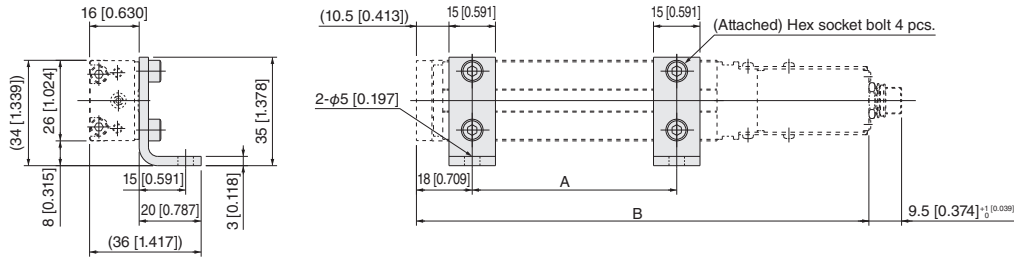

Stroke	A	B
10	16 [0.630]	96 [3.780]
30	36 [1.417]	116 [4.567]
50	66 [2.598]	146 [5.748]

●EW2G-BK2-10

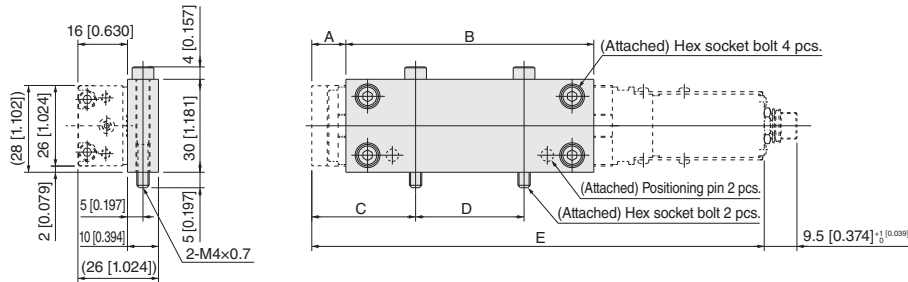

Stroke	A	B	C	D	E
10	3.5 [0.138]	45 [1.772]	8.5 [0.335]	35 [1.378]	96 [3.780]
30	3.5 [0.138]	65 [2.559]	8.5 [0.335]	55 [2.165]	116 [4.567]
50	11 [0.433]	80 [3.150]	33.5 [1.319]	35 [1.378]	146 [5.748]

●EW2G-BK3-10

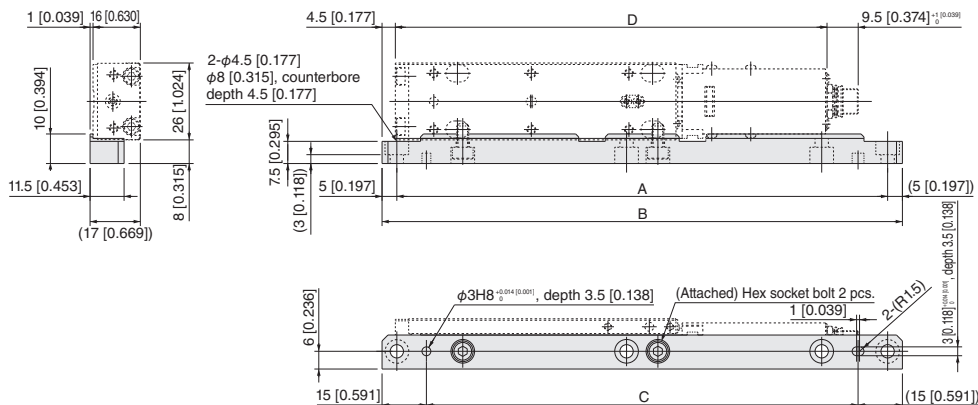

Stroke	A	B	C	D
10	116 [4.567]	126 [4.961]	96 [3.780]	96 [3.780]
30	136 [5.354]	146 [5.748]	116 [4.567]	116 [4.567]
50	166 [6.535]	176 [6.929]	146 [5.748]	146 [5.748]

* May be installed symmetrically

EW2G12 (standard type)

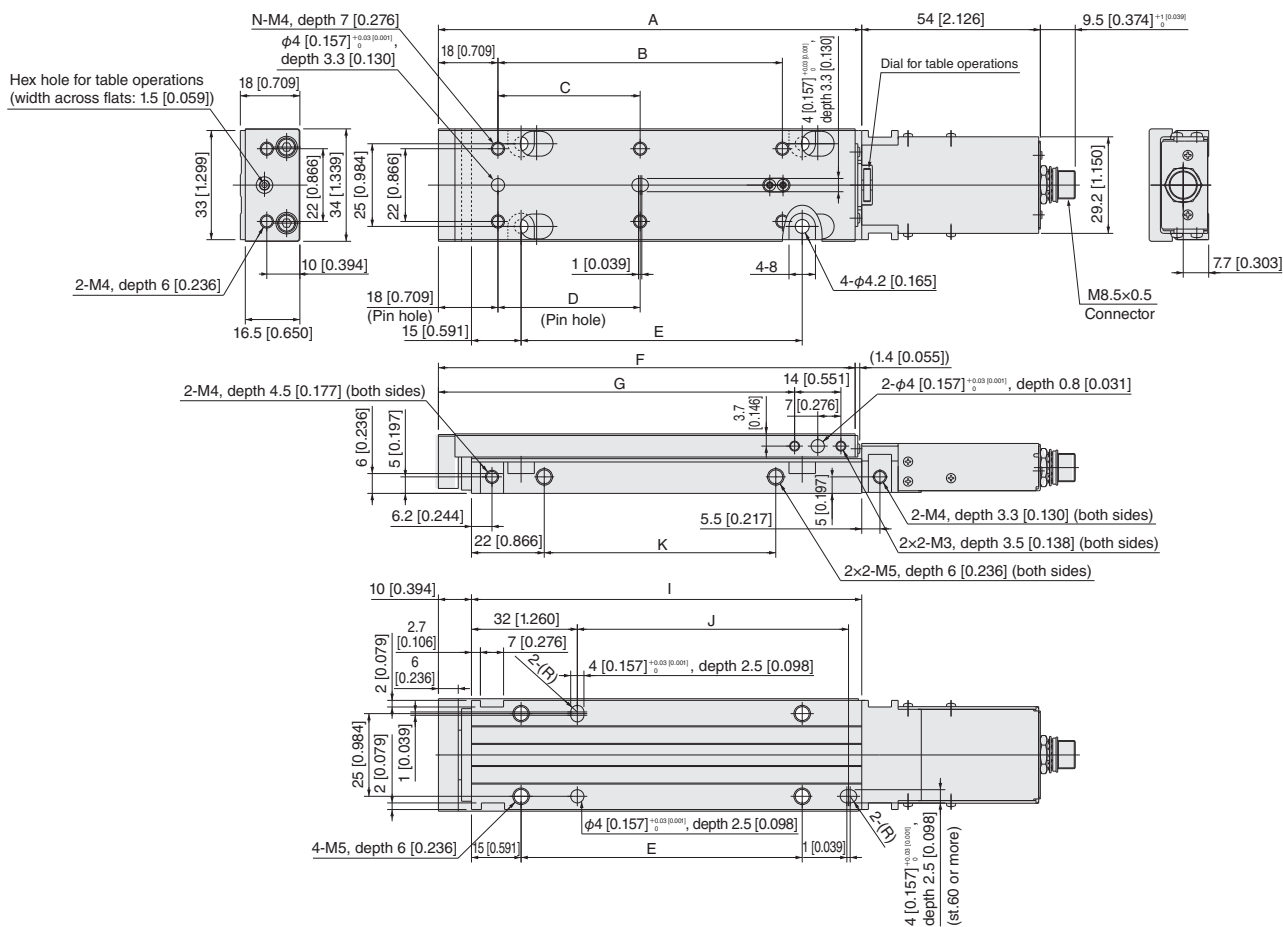

Stroke	A	B	C	D	E	F	G	I	J	K	N
20	68 [2.677]	-	26 [1.024]	16 [0.630]	25 [0.984]	66 [2.598]	47.7 [1.878]	58 [2.283]	-	25 [0.984]	4 [0.157]
40	88 [3.465]	-	46 [1.811]	36 [1.417]	45 [1.772]	86 [3.386]	67.7 [2.665]	78 [3.071]	-	25 [0.984]	4 [0.157]
60	108 [4.252]	66 [2.598]	33 [1.299]	33 [1.299]	65 [2.559]	106 [4.173]	87.7 [3.453]	98 [3.858]	62 [2.441]	50 [1.969]	6 [0.236]
80	128 [5.039]	86 [3.386]	43 [1.693]	43 [1.693]	85 [3.346]	126 [4.961]	107.7 [4.240]	118 [4.646]	82 [3.228]	70 [2.756]	6 [0.236]

Cable direction: For -1, -2, -3, or -4
(view from arrow R)

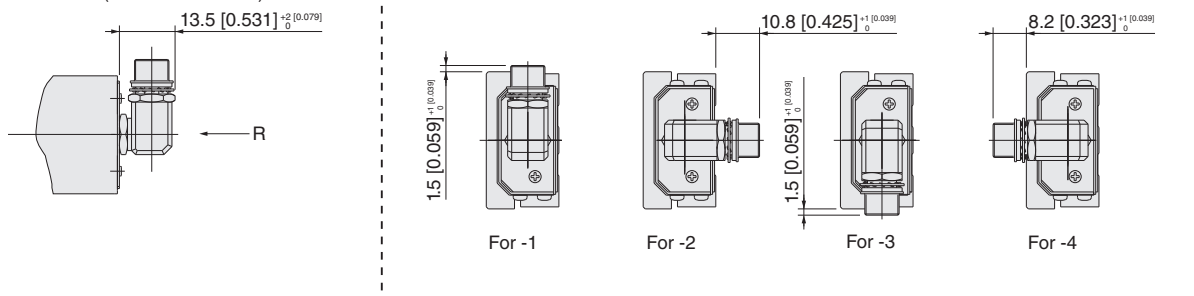

EW2G12C (Measure against foreign objects: Cover type)

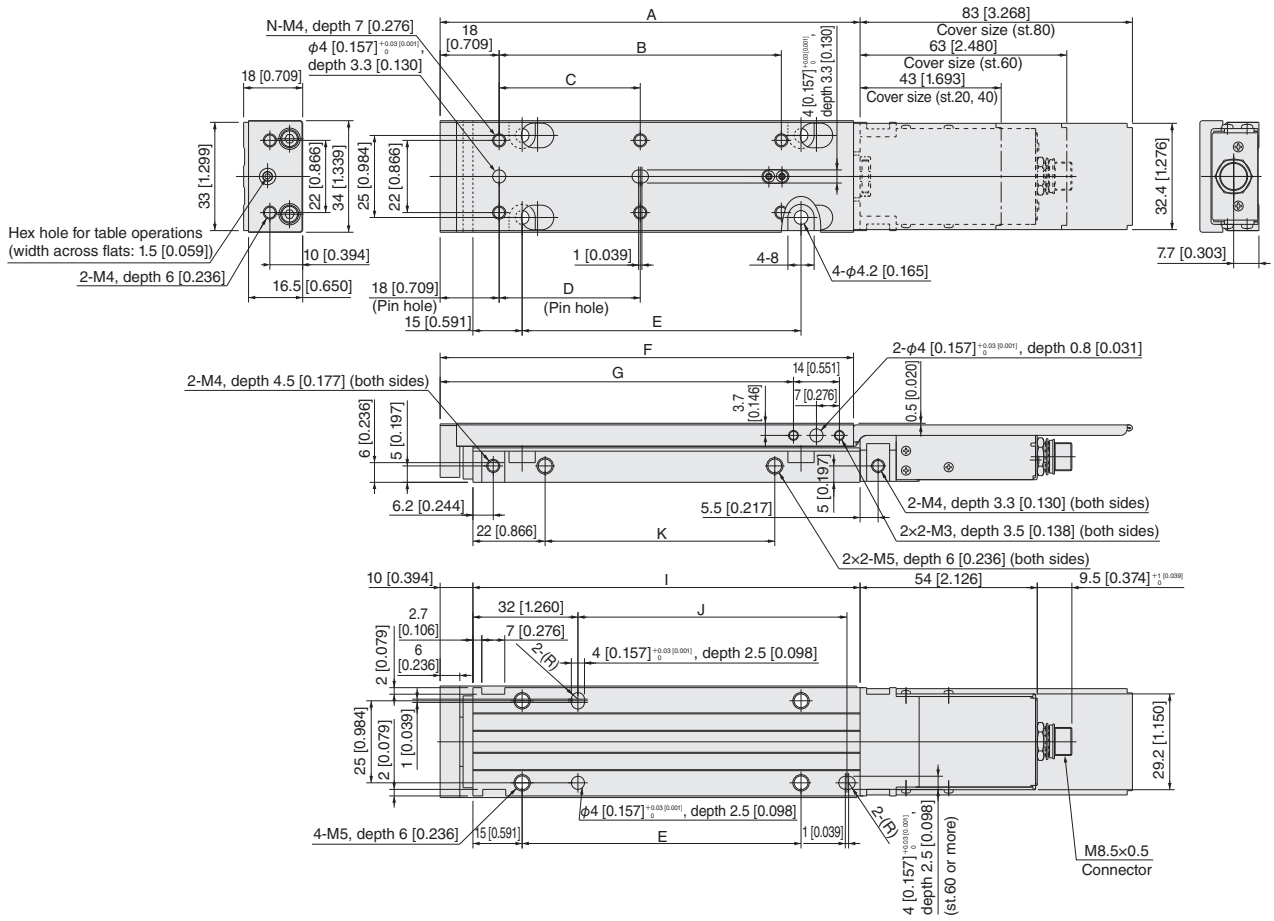

Stroke	A	B	C	D	E	F	G	I	J	K	N
20	68 [2.677]	-	26 [1.024]	16 [0.630]	25 [0.984]	66 [2.598]	47.7 [1.878]	58 [2.283]	-	25 [0.984]	4 [0.157]
40	88 [3.465]	-	46 [1.811]	36 [1.417]	45 [1.772]	86 [3.386]	67.7 [2.665]	78 [3.071]	-	25 [0.984]	4 [0.157]
60	108 [4.252]	66 [2.598]	33 [1.299]	33 [1.299]	65 [2.559]	106 [4.173]	87.7 [3.453]	98 [3.858]	62 [2.441]	50 [1.969]	6 [0.236]
80	128 [5.039]	86 [3.386]	43 [1.693]	43 [1.693]	85 [3.346]	126 [4.961]	107.7 [4.240]	118 [4.646]	82 [3.228]	70 [2.756]	6 [0.236]

Cable direction: For -1, -2, or -3
(view from arrow R)

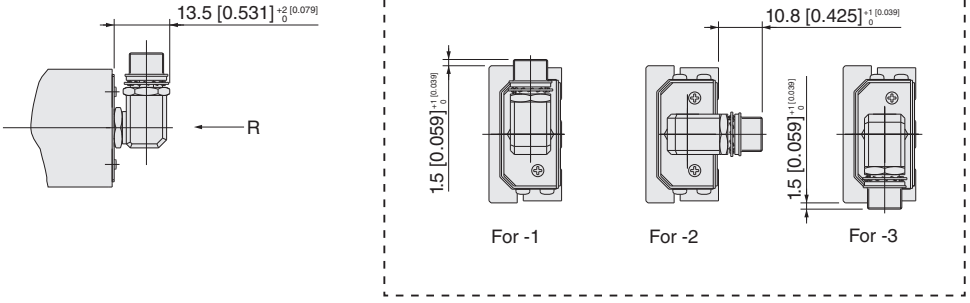

EW2G12R (Measure against foreign objects: Fixed table type)

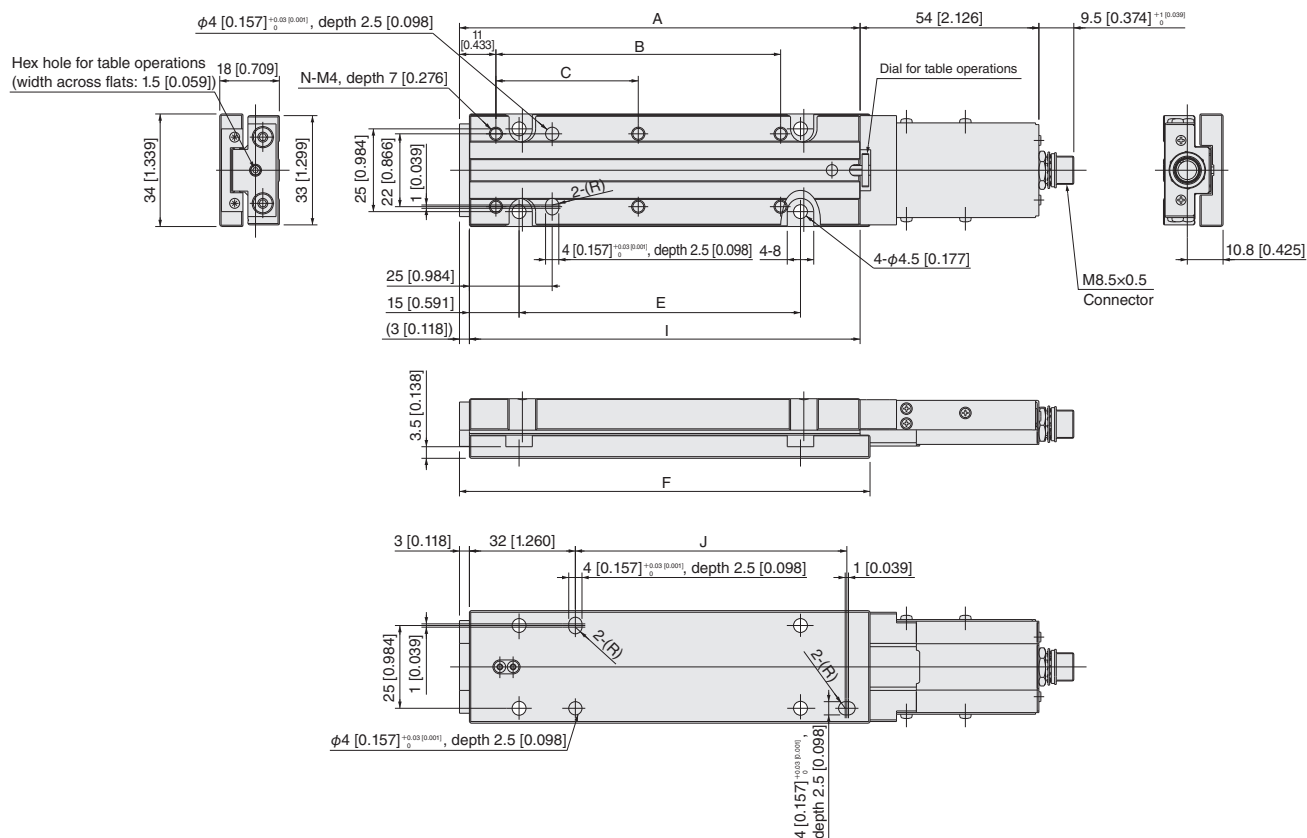

Stroke	A	B	C	E	F	I	J	N
20	61 [2.402]	-	26 [1.024]	25 [0.984]	64 [2.520]	58 [2.283]	-	4 [0.157]
40	81 [3.189]	-	46 [1.811]	45 [1.772]	84 [3.307]	78 [3.071]	-	4 [0.157]
60	101 [3.976]	66 [2.598]	33 [1.299]	65 [2.559]	104 [4.094]	98 [3.858]	62 [2.441]	6 [0.236]
80	121 [4.764]	86 [3.386]	43 [1.693]	85 [3.346]	124 [4.882]	118 [4.646]	82 [3.228]	6 [0.236]

● Dimensions with the connecting cable mounted and dimensions with the cable bent (reference values)

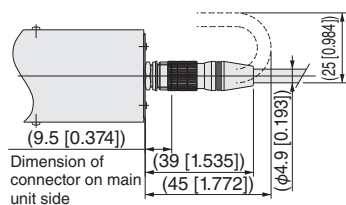

Note) As is the case with different cable directions, the dimensions with the connecting cable mounted are longer than those with the connecting cable not mounted by +30 mm [1.181 in.] or so.

EW2G12 - **Stroke** - **MS** (w/ stroke adjustment mechanism and bracket set)

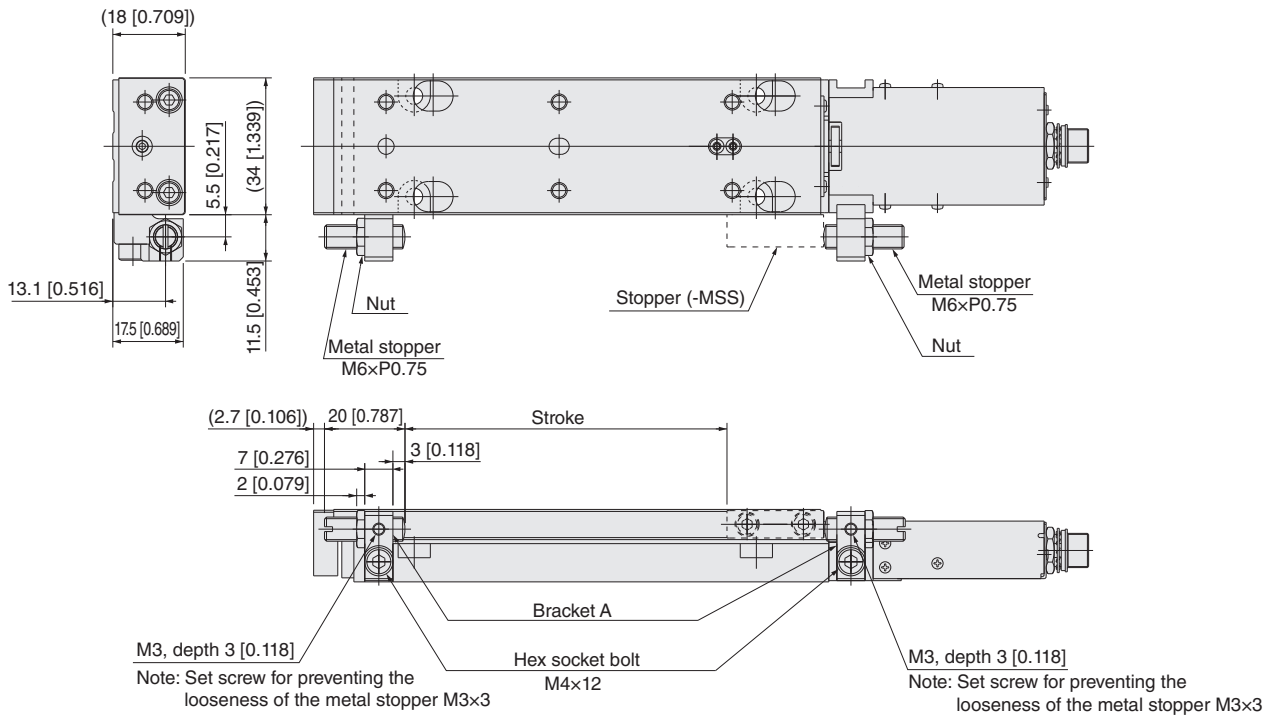

EW2G12 - **Stroke** - **MS** (w/ stroke adjustment mechanism and stopper set)

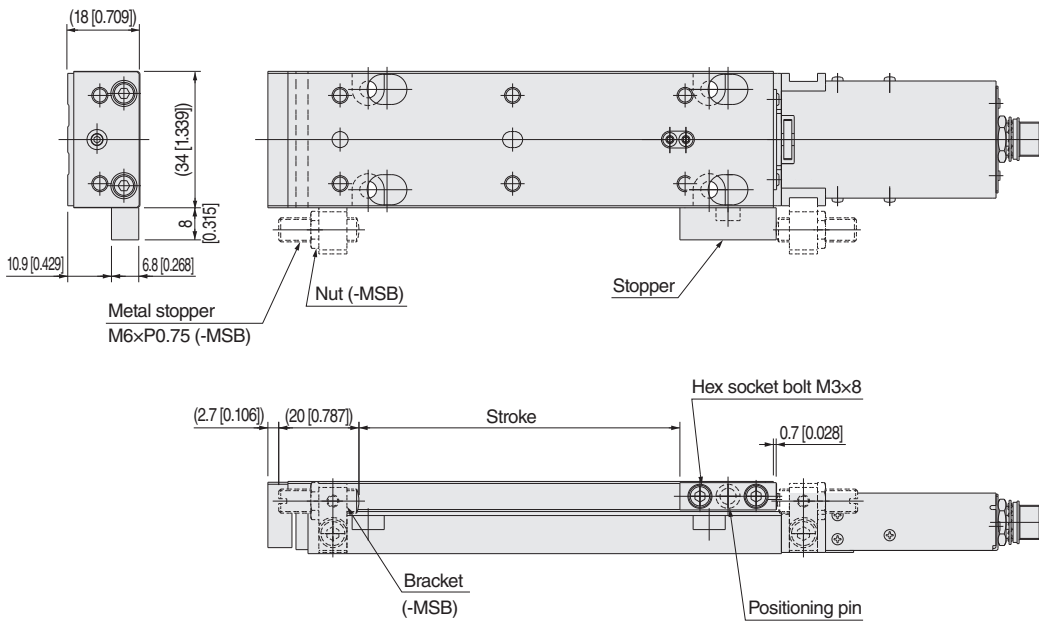

Vertical bracket (additional parts)

●EW2G-BK1-12

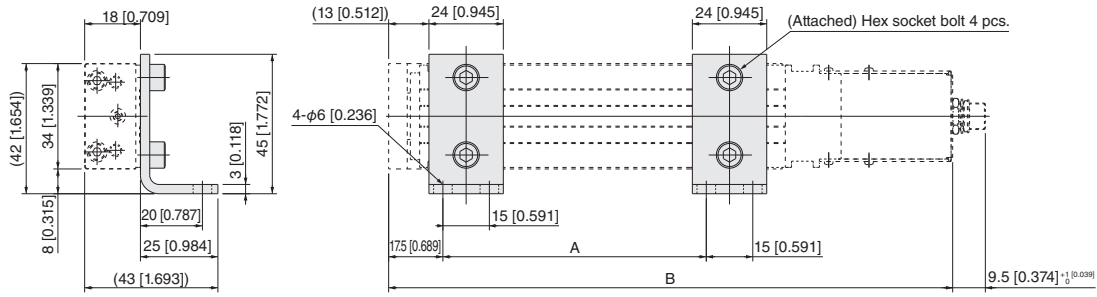

Stroke	A	B
20	25 [0.984]	122 [4.803]
40	45 [1.772]	142 [5.591]
60	65 [2.559]	162 [6.378]
80	85 [3.346]	182 [7.165]

●EW2G-BK2-12

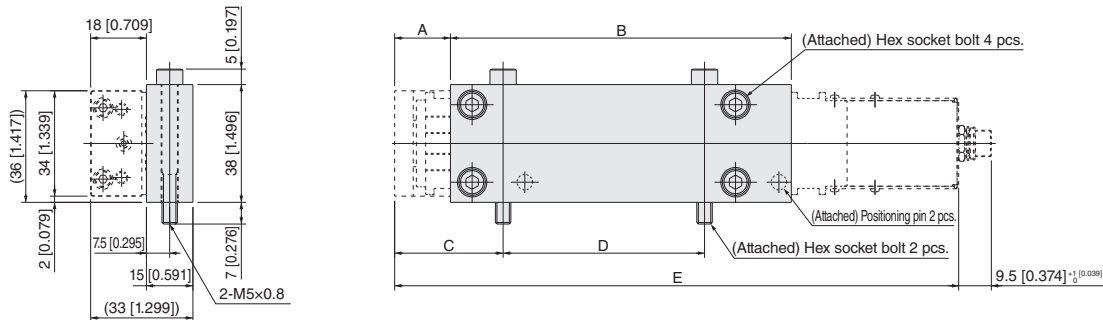

Stroke	A	B	C	D	E
20	10 [0.394]	55 [2.165]	15 [0.591]	45 [1.772]	122 [4.803]
40	17.5 [0.689]	60 [2.362]	35 [1.378]	25 [0.984]	142 [5.591]
60	18 [0.709]	90 [3.543]	35 [1.378]	45 [1.772]	162 [6.378]
80	18 [0.709]	110 [4.331]	35 [1.378]	65 [2.559]	182 [7.165]

●EW2G-BK3-12

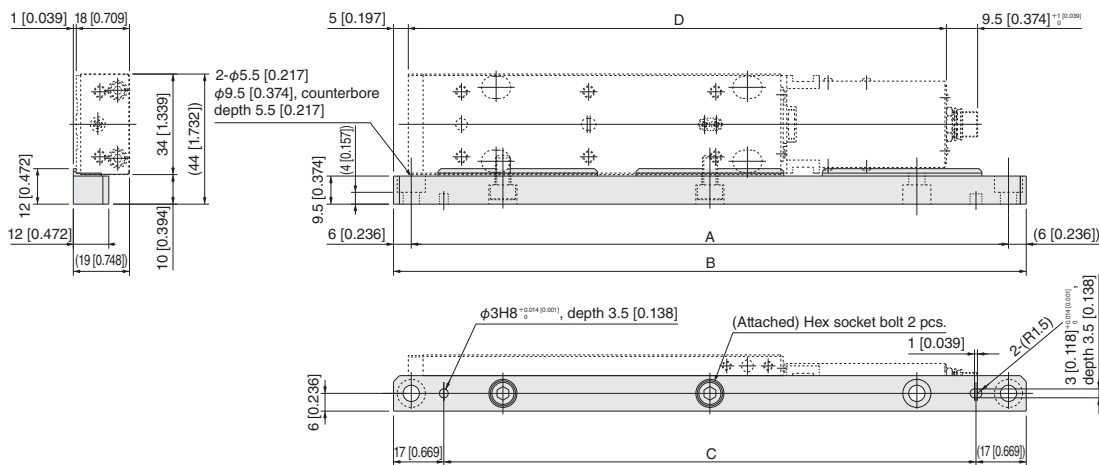

Stroke	A	B	C	D
20	142 [5.591]	154 [6.063]	120 [4.724]	122 [4.803]
40	162 [6.378]	174 [6.850]	140 [5.512]	142 [5.591]
60	182 [7.165]	194 [7.638]	160 [6.299]	162 [6.378]
80	202 [7.953]	214 [8.425]	180 [7.087]	182 [7.165]

* May be installed symmetrically

Thin Electric Slider Dimensions (mm [in.])

EW2G16 (standard type)

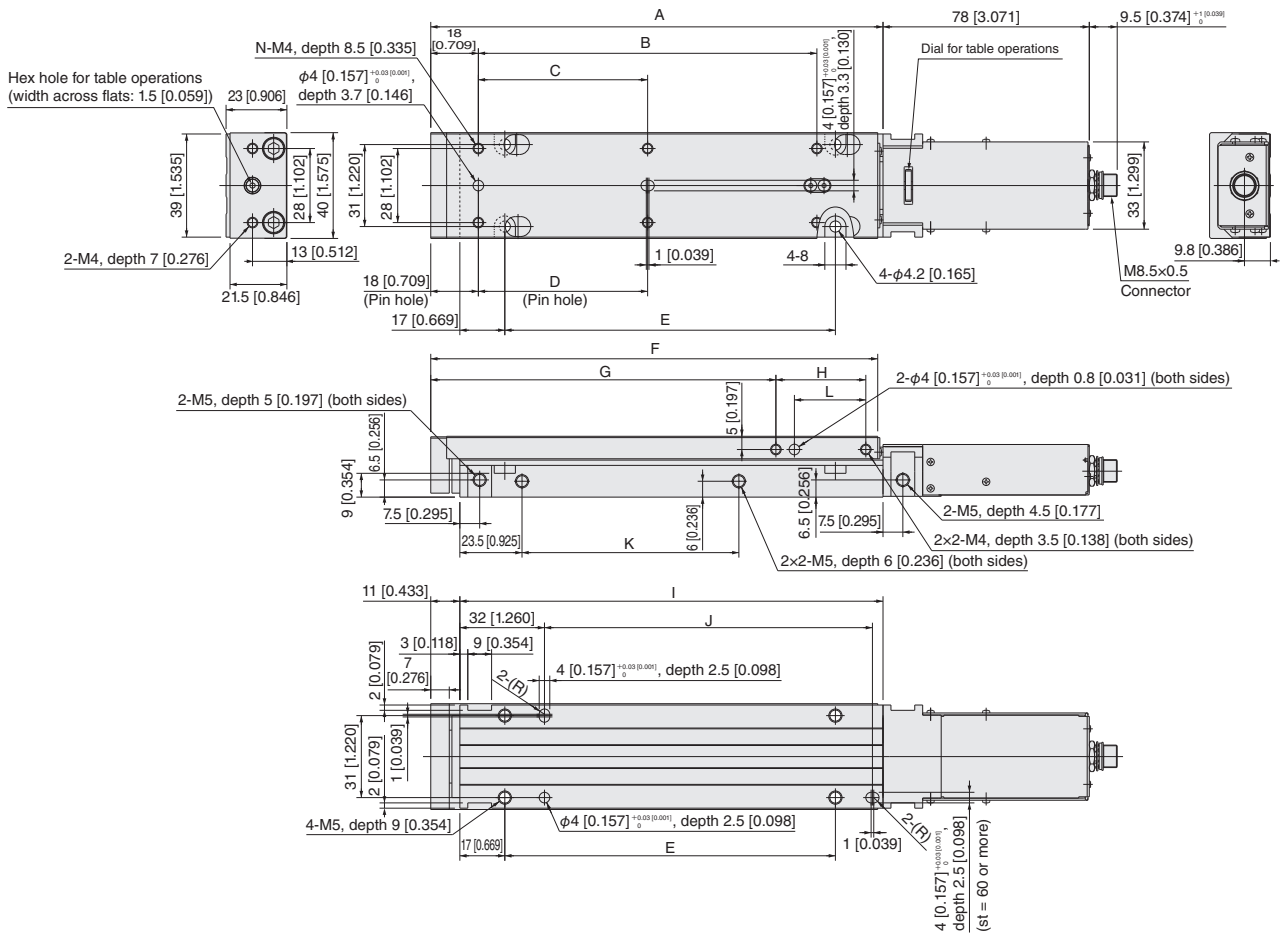

Stroke	A	B	C	D	E	F	G	H	I	J	K	L	N
20	71 [2.795]	-	28 [1.102]	18 [0.709]	25 [0.984]	69 [2.717]	50.5 [1.988]	14 [0.551]	60 [2.362]	-	12 [0.472]	7 [0.276]	4 [0.157]
40	91 [3.583]	-	48 [1.890]	38 [1.496]	45 [1.772]	89 [3.504]	70.5 [2.776]	14 [0.551]	80 [3.150]	-	32 [1.260]	7 [0.276]	4 [0.157]
60	111 [4.370]	68 [2.677]	34 [1.339]	34 [1.339]	65 [2.559]	109 [4.291]	90.5 [3.563]	14 [0.551]	100 [3.937]	64 [2.520]	42 [1.654]	7 [0.276]	6 [0.236]
100	171 [6.732]	128 [5.039]	64 [2.520]	64 [2.520]	125 [4.921]	169 [6.654]	130.5 [5.138]	34 [1.339]	160 [6.299]	124 [4.882]	82 [3.228]	27 [1.063]	6 [0.236]

Cable direction: For -1, -2, -3, or -4
(view from arrow R)

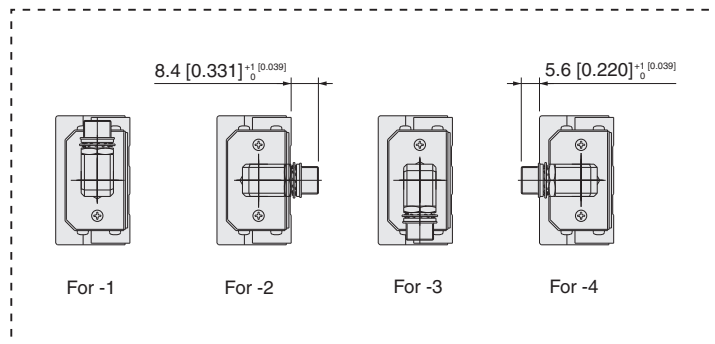
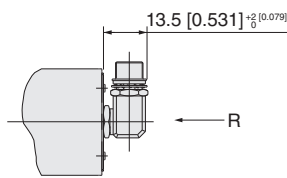

EW2G16C (Measure against foreign objects: Cover type)

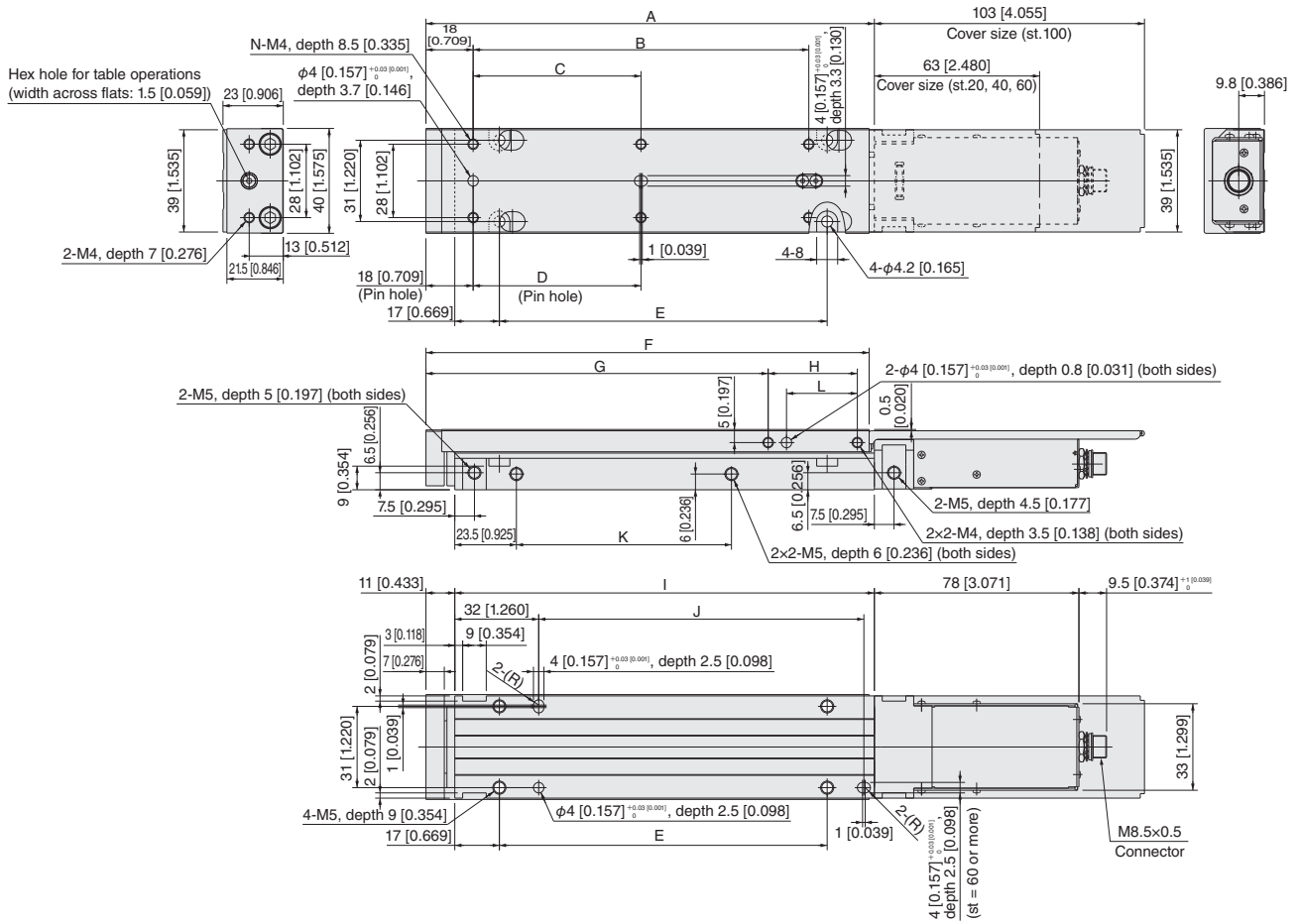

Stroke	A	B	C	D	E	F	G	H	I	J	K	L	N
20	71 [2.795]	-	28 [1.102]	18 [0.709]	25 [0.984]	69 [2.717]	50.5 [1.988]	14 [0.551]	60 [2.362]	-	12 [0.472]	7 [0.276]	4 [0.157]
40	91 [3.583]	-	48 [1.890]	38 [1.496]	45 [1.772]	89 [3.504]	70.5 [2.776]	14 [0.551]	80 [3.150]	-	32 [1.260]	7 [0.276]	4 [0.157]
60	111 [4.370]	68 [2.677]	34 [1.339]	34 [1.339]	65 [2.559]	109 [4.291]	90.5 [3.563]	14 [0.551]	100 [3.937]	64 [2.520]	42 [1.654]	7 [0.276]	6 [0.236]
100	171 [6.732]	128 [5.039]	64 [2.520]	64 [2.520]	125 [4.921]	169 [6.654]	130.5 [5.138]	34 [1.339]	160 [6.299]	124 [4.882]	82 [3.228]	27 [1.063]	6 [0.236]

Cable direction: For -1, -2, or -3
(view from arrow R)

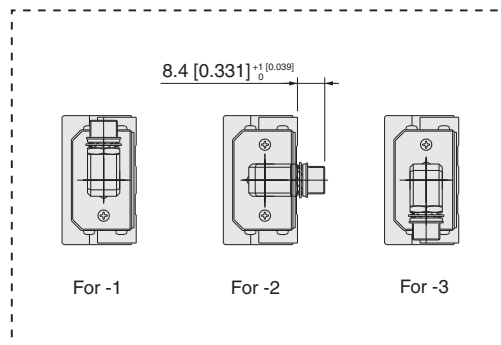
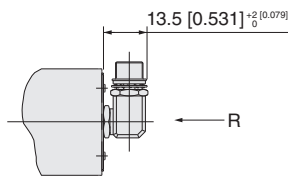

EW2G16R (Measure against foreign objects: Fixed table type)

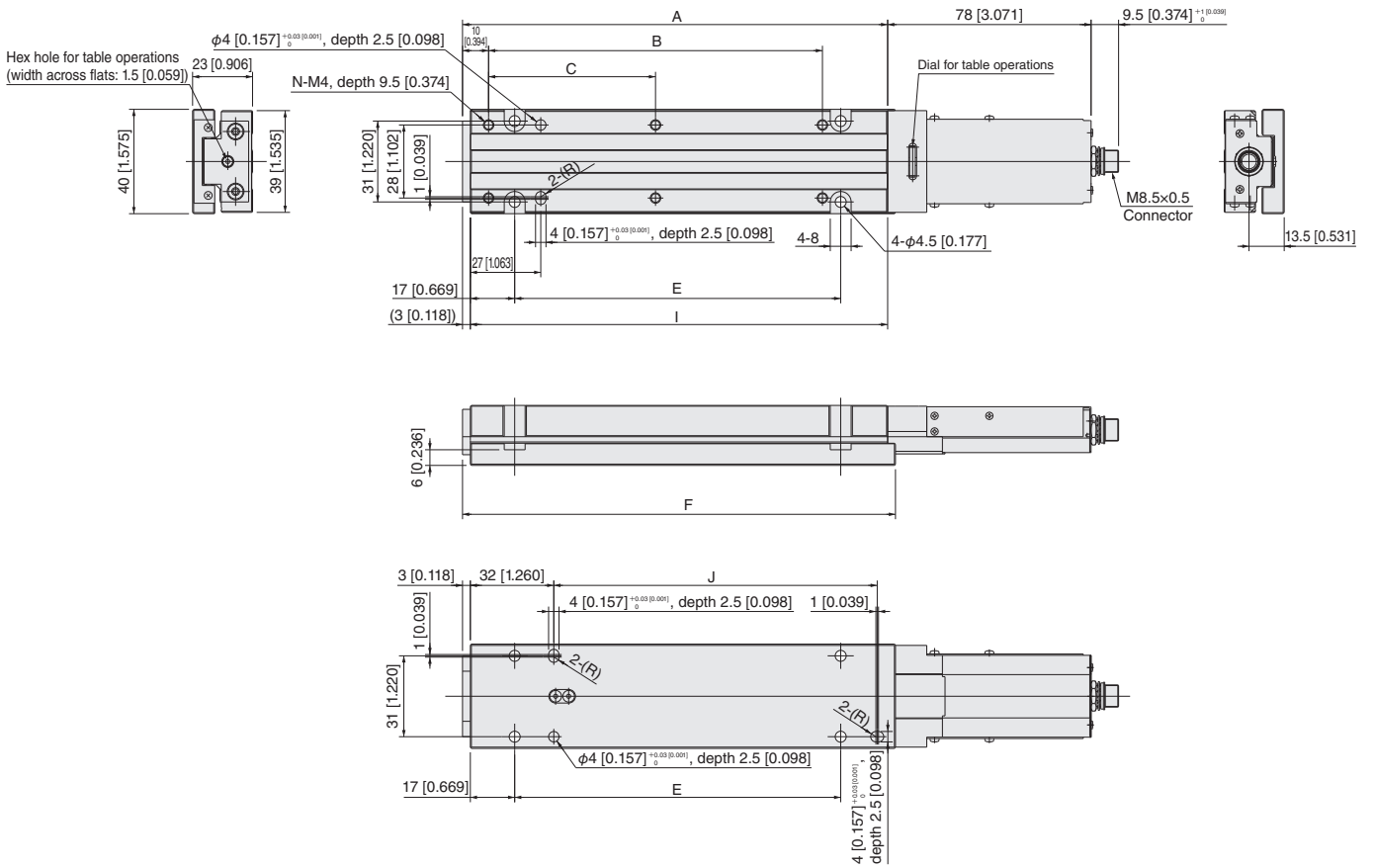

Stroke	A	B	C	E	F	I	J	N
20	63 [2.480]	-	28 [1.102]	25 [0.984]	66 [2.598]	60 [2.362]	-	4 [0.157]
40	83 [3.268]	-	48 [1.890]	45 [1.772]	86 [3.386]	80 [3.150]	-	4 [0.157]
60	103 [4.055]	68 [2.677]	34 [1.339]	65 [2.559]	106 [4.173]	100 [3.937]	64 [2.520]	6 [0.236]
100	163 [6.417]	128 [5.039]	64 [2.520]	125 [4.921]	166 [6.535]	160 [6.299]	124 [4.882]	6 [0.236]

● Dimensions with the connecting cable mounted and dimensions with the cable bent (reference values)

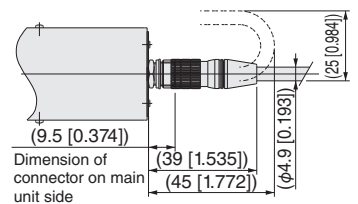

Note) As is the case with different cable directions, the dimensions with the connecting cable mounted are longer than those with the connecting cable not mounted by +30 mm [1.181 in.] or so.

EW2G16 - **Stroke** - **MS** (w/ stroke adjustment mechanism and bracket set)

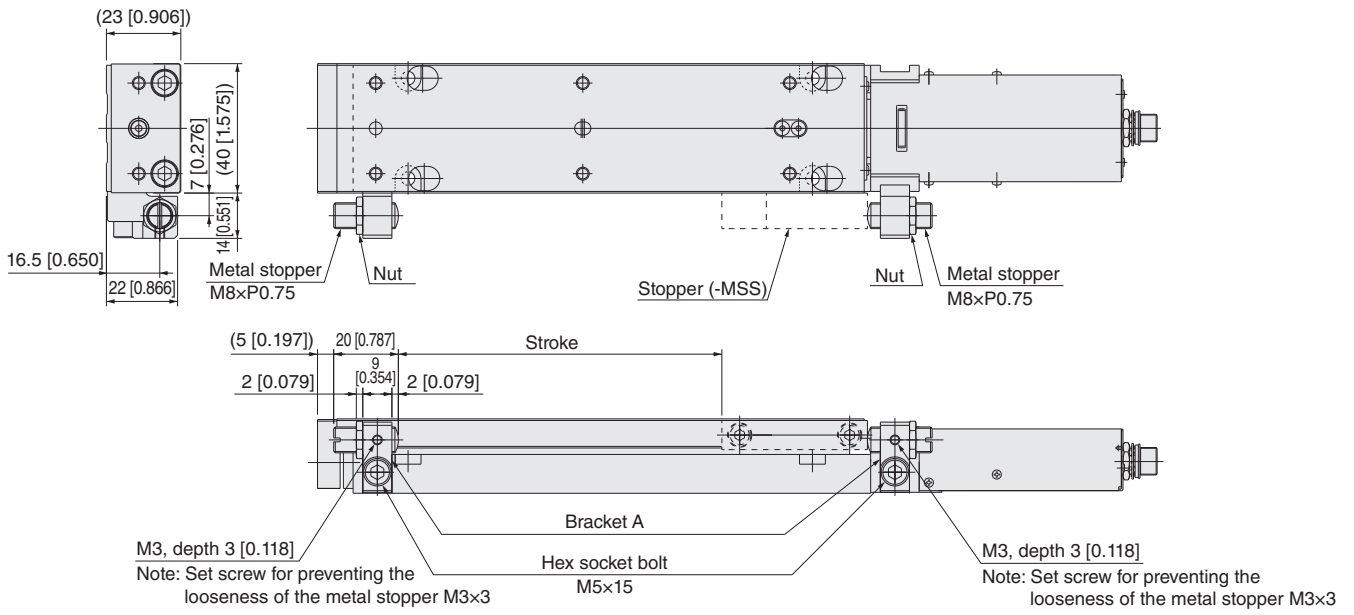

EW2G16 - **Stroke** - **MS** (w/ stroke adjustment mechanism and stopper set)

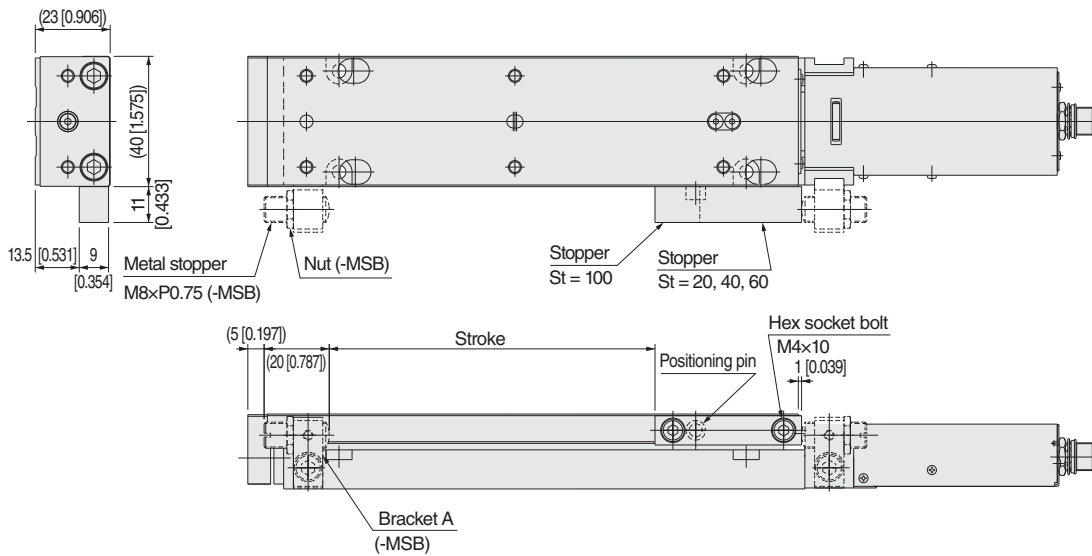

Vertical bracket (additional parts)

●EW2G-BK1-16

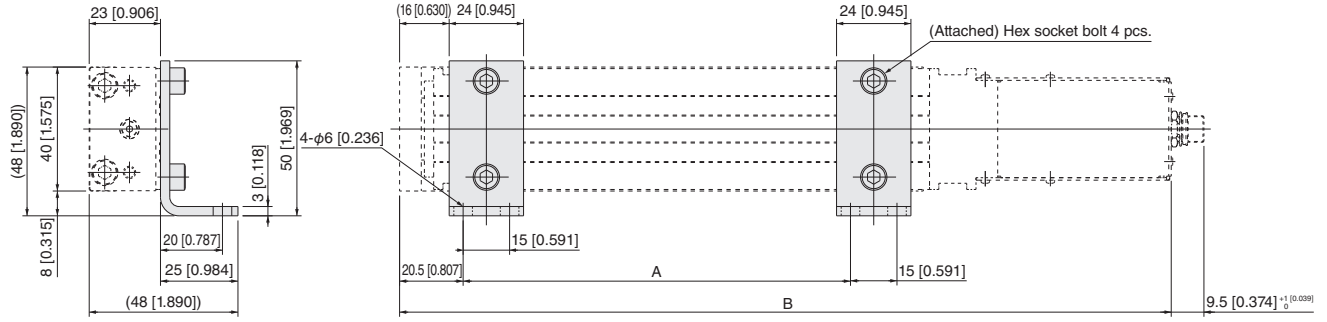

Stroke	A	B
20	25 [0.984]	149 [5.866]
40	45 [1.772]	169 [6.654]
60	65 [2.559]	189 [7.441]
100	125 [4.921]	249 [9.803]

●EW2G-BK2-16

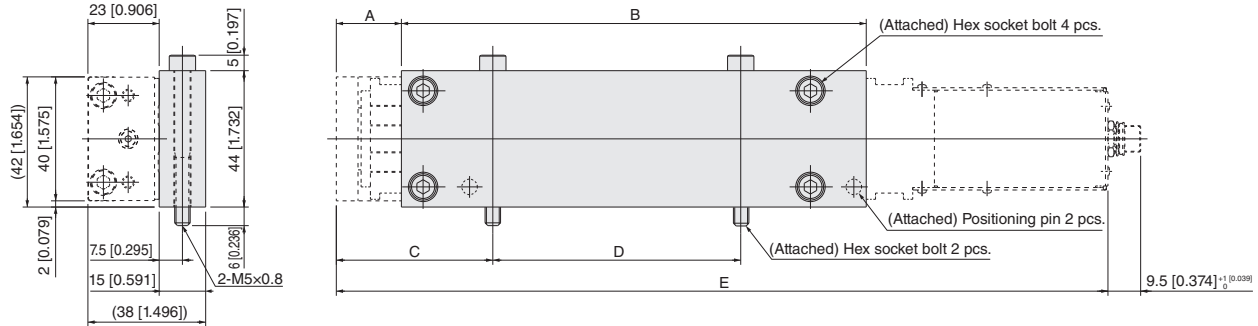

Stroke	A	B	C	D	E
20	13 [0.512]	55 [2.165]	18 [0.709]	45 [1.772]	149 [5.866]
40	20.5 [0.807]	60 [2.362]	37.5 [1.476]	26 [1.024]	169 [6.654]
60	21 [0.827]	90 [3.543]	37.5 [1.476]	46 [1.811]	189 [7.441]
100	21 [0.827]	150 [5.906]	50.5 [1.988]	80 [3.150]	249 [9.803]

●EW2G-BK3-16

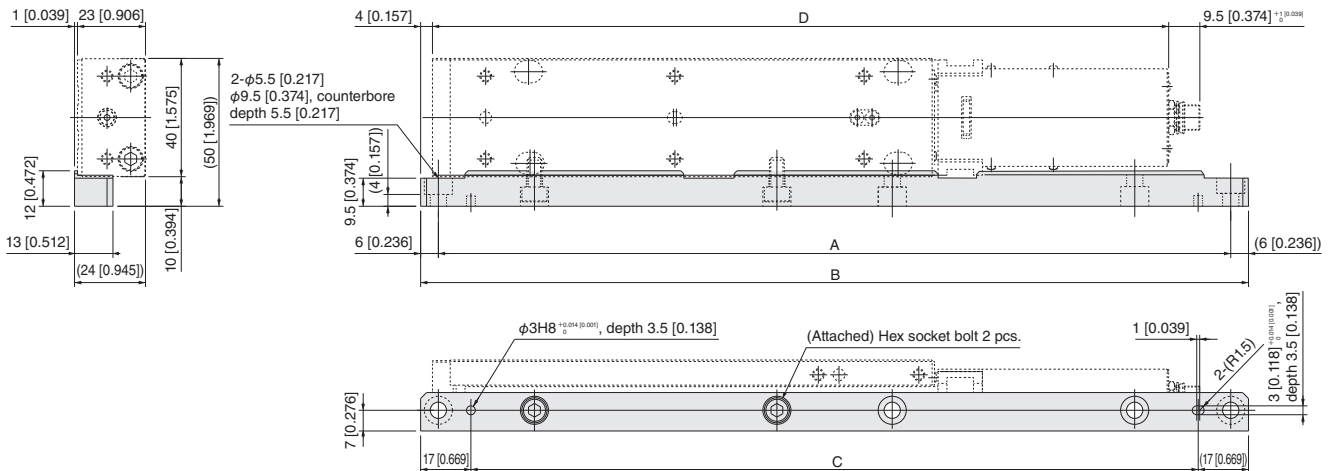

Stroke	A	B	C	D
20	168 [6.614]	180 [7.087]	146 [5.748]	149 [5.866]
40	188 [7.402]	200 [7.874]	166 [6.535]	169 [6.654]
60	208 [8.189]	220 [8.661]	186 [7.323]	189 [7.441]
100	268 [10.551]	280 [11.024]	246 [9.685]	249 [9.803]

* May be installed symmetrically

Controller

Point input type
NPN specifications



Specifications

Item	Model	EW2C-H-NP
Control specifications	Motor drive method	Square wave drive
	Control method	Closed loop control ^{Note 1}
	Operating method	PTP, force control
	Origin detection method	Detection at the stroke end
	Location detection method	Hall IC output
	Minimum setting distance	0.05 mm [0.002 in.]
	Point setting	32 points
	Point input method	Numeric input, teaching input, direct teaching
	Point setting input	5 points (POS0 to POS4)
	Control input	3 points (ORG, START, and STOP)
	Control output	4 points (READY, BUSY, HOLD, and INPOS)
	Abnormality detection output	Overtimes, disconnection, incorrect data, system abnormality
	Motor drive cable	Dedicated cables for motor drive output and Hall IC input (F.G., shielded)
	Hall IC cable	
RS485 communication method	External communications	RS485 1ch (Communication with computer or teaching box) Daisy chain available (up to 16 units)
	Communication method	Half duplex
	Synchronization method	Asynchronous method
	Transmission rate	115.2kbps
	Parity bit	Odd number
	Communication distance	Total cable length 100 m [328.0 ft] or less
Communication cable	Dedicated cable (2 twisted pair shielded cables)	
General specifications	Mass	0.2 kg [0.441 lb]
	Power supply	DC24V±10% 1.6A MAX (Used also as a power supply for RS485 communication)
	Power supply indication	PWR
	Operating temperature range	0 to 40°C [32 to 104°F]
	Operating humidity range	35 to 85% RH (no condensation)
	Storage temperature range	-10 to 65°C [14 to 149°F]
	Back-up	EEPROM used to maintain setting conditions
	Noise resistance	IEC61000-4-4 level 3
Accessories	I/O cable, power cable	

Note 1: A Hall IC is used for step out detection.

Controller wiring method

1. When the controller's internal power supply is used

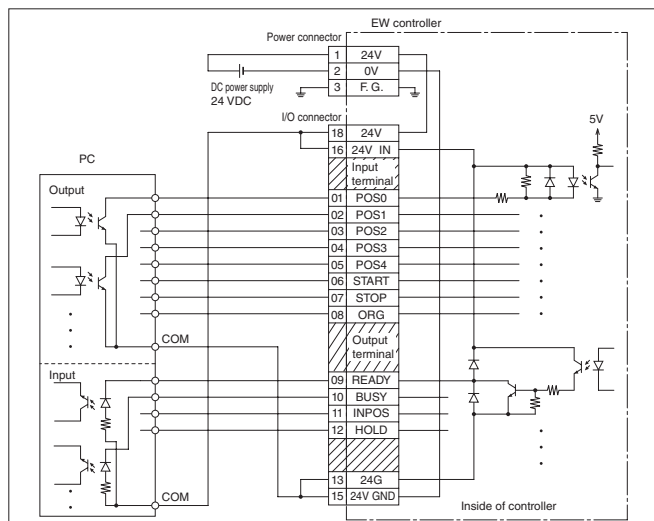

2. When the controller's internal power supply is not used

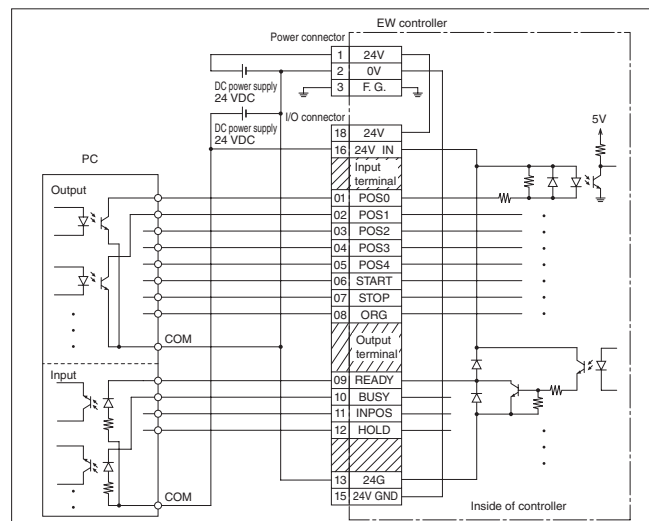

Controller

Point input type
PNP specifications



Specifications

Item	Model	EW2C-H-PN
Control specifications	Motor drive method	Square wave drive
	Control method	Closed loop control ^{Note 1}
	Operating method	PTP, force control
	Origin detection method	Detection at the stroke end
	Location detection method	Hall IC output
	Minimum setting distance	0.05 mm [0.002 in.]
	Point setting	32 points
	Point input method	Numeric input, teaching input, direct teaching
	Point setting input	5 points (POS0 to POS4)
	Control input	3 points (ORG, START, and STOP)
	Control output	4 points (READY, BUSY, HOLD, and INPOS)
	Abnormality detection output	Overtimes, disconnection, incorrect data, system abnormality
	Motor drive cable	Dedicated cables for motor drive output and Hall IC input (F.G., shielded)
	Hall IC cable	
RS485 communication method	External communications	RS485 1ch (Communication with computer or teaching box) Daisy chain available (up to 16 units)
	Communication method	Half duplex
	Synchronization method	Asynchronous method
	Transmission rate	115.2kbps
	Parity bit	Odd number
	Communication distance	Total cable length 100 m [328.0 ft] or less
	Communication cable	Dedicated cable (2 twisted pair shielded cables)
General specifications	Mass	0.2 kg [0.441 lb]
	Power supply	DC24V±10% 1.6A MAX (Used also as a power supply for RS485 communication)
	Power supply indication	PWR
	Operating temperature range	0 to 40°C [32 to 104°F]
	Operating humidity range	35 to 85% RH (no condensation)
	Storage temperature range	-10 to 65°C [14 to 149°F]
	Back-up	EEPROM used to maintain setting conditions
	Noise resistance	IEC61000-4-4 level 3
Accessories	I/O cable, power cable	

Note 1: A Hall IC is used for step out detection.

Controller wiring method

1. When the controller's internal power supply is used

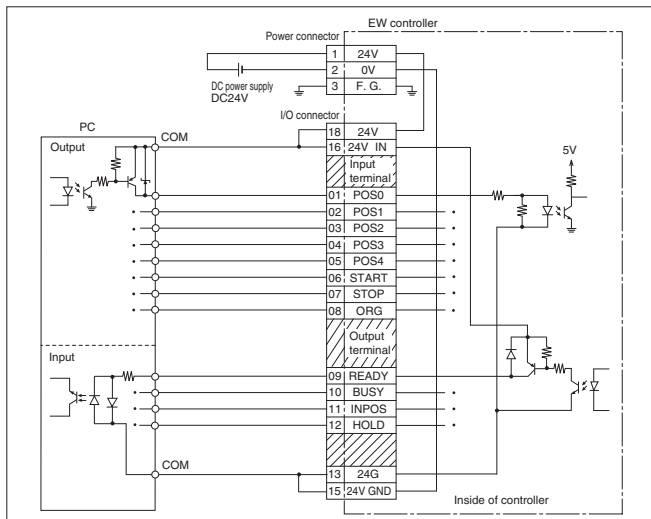

2. When the controller's internal power supply is not used

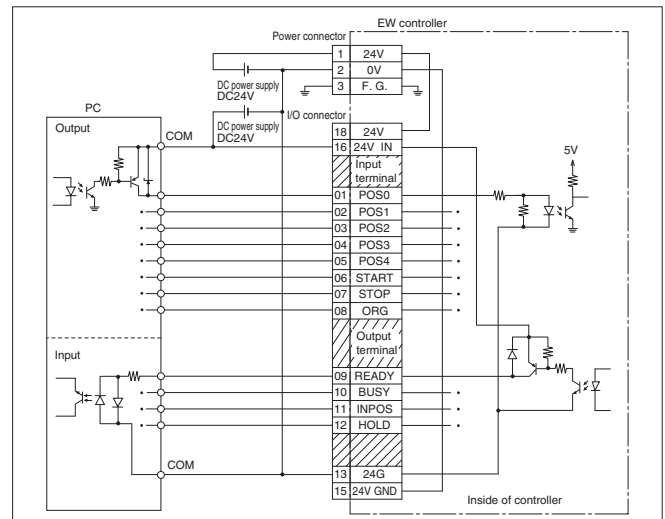

Controller

CC-Link remote I/O type



Specifications

Item	Model	EW2C-H-CC					
Control specifications	Motor drive method	Square wave drive					
	Control method	Closed loop control ^{Note 1}					
	Operating method	PTP, force control					
	Origin detection method	Detection at the stroke end					
	Location detection method	Hall IC output					
	Minimum setting distance	0.05 mm [0.002 in.]					
	Point setting	32 points					
	Point input method	Numeric input, teaching input, direct teaching					
	Point setting input	5 points (POS0 to POS4)					
	Control input	3 points (ORG, START, and STOP)					
	Control output	4 points (READY, BUSY, HOLD, and INPOS)					
	Abnormality detection output	Overtimes, disconnection, incorrect data, system abnormality					
	Motor drive cable	Dedicated cables for motor drive output and Hall IC input (F.G., shielded)					
	Hall IC cable						
RS485 communication method	External communications	RS485 1ch (Communication with computer or teaching box) Daisy chain available (up to 16 units)					
	Communication method	Half duplex					
	Synchronization method	Asynchronous method					
	Transmission rate	115.2kbps					
	Parity bit	Odd number					
	Communication distance	Total cable length 100 m [328.0 ft] or less					
	Communication cable	Dedicated cable (2 twisted pair shielded cables)					
General specifications	Mass	0.2 kg [0.441 lb]					
	Power supply	DC24V±10% 1.6A MAX (Used also as power supplies for CC-Link communication and RS485 communication)					
	Power supply indication	PWR					
	Operating temperature range	0 to 40°C [32 to 104°F]					
	Operating humidity range	35 to 85% RH (no condensation)					
	Storage temperature range	-10 to 65°C [14 to 149°F]					
	Back-up	EEPROM used to maintain setting conditions					
	Noise resistance	IEC61000-4-4 level 3					
	Accessories	CC-Link connector, power cable, CC-Link terminating resistor					
CC-Link communication specifications	Version	Ver.1.10					
	Communication method	Broadcast polling method					
	Synchronization method	Frame synchronization method					
	Transmission method	Bus type (EIA RS485-compliant)					
	Transmission rate	156k/625k/2.5M/5M/10Mbps changed by switch (rotary switch)					
	Number of occupied stations	1 remote I/O station					
	Maximum number of units that can be connected	64 units					
	Station number setting	1 to 64, selectable with a switch (rotary switch)					
	CLEAR/HOLD	Selectable with a switch (DIP switch) CLEAR: Clears all settings, except the controller connection setting, in case of a CC-Link communication error HOLD: Maintains the state immediately before the occurrence of the error in case of a CC-Link communication error					
	Indication	PW, L RUN, SD, RD, L ERR (LED: Red)					
	Transmission distance	Transmission rate bps	156k	625k	2.5M	5M	10M
		Total cable length m [ft]	1200 [3936]	900 [2952]	400 [1312]	160 [524.8]	100 [328.0]
	Communication cable	Ver.1.10-compatible CC-Link dedicated cable					
Terminating resistor	110 Ω (when a Ver.1.10-compatible CC-Link dedicated cable is used)						

Note 1: A Hall IC is used for step out detection.

Controller

CC-Link remote device type



Specifications

Item	Model	EW2C-H-CCD					
Control specifications	Motor drive method	Square wave drive					
	Control method	Closed loop control ^{Note 1}					
	Operating method	PTP, force control					
	Origin detection method	Detection at the stroke end					
	Location detection method	Hall IC output					
	Minimum setting distance	0.05 mm [0.002 in.]					
	Point setting	32 points					
	Point input method	Numeric input, teaching input, direct teaching					
	Point setting input	5 points (POS0 to POS4)					
	Abnormality detection output	Overtimes, disconnection, incorrect data, system abnormality					
	Motor drive cable	Dedicated cables for motor drive output and Hall IC input (F.G., shielded)					
	Hall IC cable						
RS485 communication method	External communications	RS485 1ch (Communication with computer or teaching box) Daisy chain available (up to 16 units)					
	Communication method	Half duplex					
	Synchronization method	Asynchronous method					
	Transmission rate	115.2kbps					
	Parity bit	Odd number					
	Communication distance	Total cable length 100 m [328.0 ft] or less					
	Communication cable	Dedicated cable (2 twisted pair shielded cables)					
General specifications	Mass	0.2 kg [0.441 lb]					
	Power supply	DC24V±10% 1.6A MAX (Used also as power supplies for CC-Link communication and RS485 communication)					
	Power supply indication	PWR					
	Operating temperature range	0 to 40°C [32 to 104°F]					
	Operating humidity range	35 to 85% RH (no condensation)					
	Storage temperature range	-10 to 65°C [14 to 149°F]					
	Back-up	FRAM used to maintain setting conditions					
	Noise resistance	IEC61000-4-4 level 3					
Accessories	CC-Link connector, power cable, CC-Link terminating resistor						
CC-Link communication specifications	Version	Ver.1.10					
	Communication method	Broadcast polling method					
	Synchronization method	Frame synchronization method					
	Transmission method	Bus type (EIA RS485-compliant)					
	Transmission rate	156k/625k/2.5M/5M/10Mbps changed by switch (rotary switch)					
	Number of occupied stations	Remote device stations 1 station/2 stations/4 stations (Switching parameters)					
	Maximum number of units that can be connected	When one station is occupied: 42 units When two stations are occupied: 32 units When four stations are occupied: 16 units Selectable with a switch (rotary switch)					
	Station number setting	When one station is occupied: 1 to 64 When two stations are occupied: 1 to 63 When four stations are occupied: 1 to 61 Selectable with a switch (DIP switch)					
	CLEAR/HOLD	CLEAR: Clears all settings, except the controller connection setting, in case of a CC-Link communication error HOLD: Maintains the state immediately before the occurrence of the error in case of a CC-Link communication error					
	Indication	PW, L RUN, SD, RD, L ERR (LED: Blue)					
	Transmission distance	Transmission rate bps	156k	625k	2.5M	5M	10M
		Total cable length m [ft]	1200 [3936]	900 [2952]	400 [1312]	160 [524.8]	100 [328.0]
	Communication cable	Ver.1.10-compatible CC-Link dedicated cable					
Terminating resistor	110 Ω (when a Ver. 1.10-compatible CC-Link dedicated cable is used)						

Note 1: A Hall IC is used for step out detection.

Dimensions (mm [in.])

● Controller

Point input type EW2C-H-

DIN rail mounting plate
Blank: w/o mounting plate
DP: w/ mounting plate

Controller type
NP: Point input type (NPN model)
PN: Point input type (PNP model)

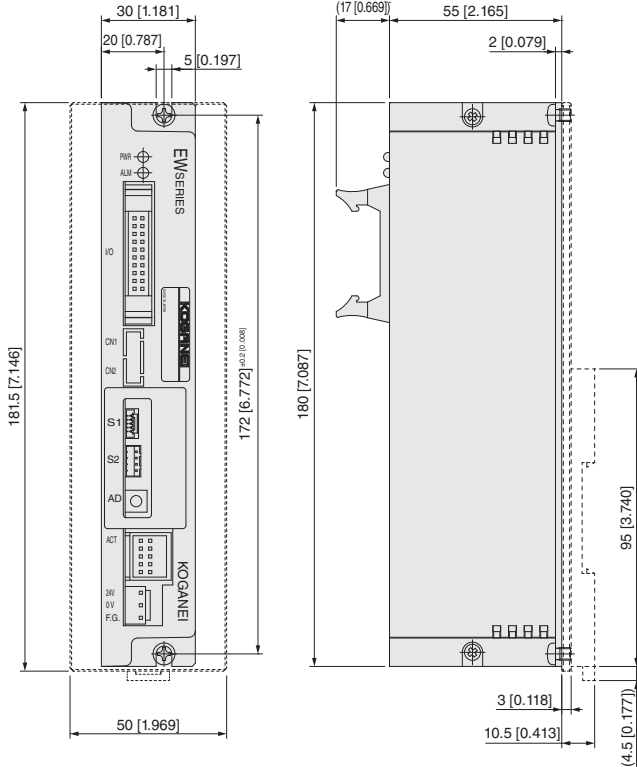

* The dotted lines indicate the dimensions of the DIN rail mounting plate

CC-Link type EW2C-H-

DIN rail mounting plate
Blank: w/o mounting plate
DP: w/ mounting plate

Controller type
CC: CC-Link remote I/O type
CCD: CC-Link remote device type

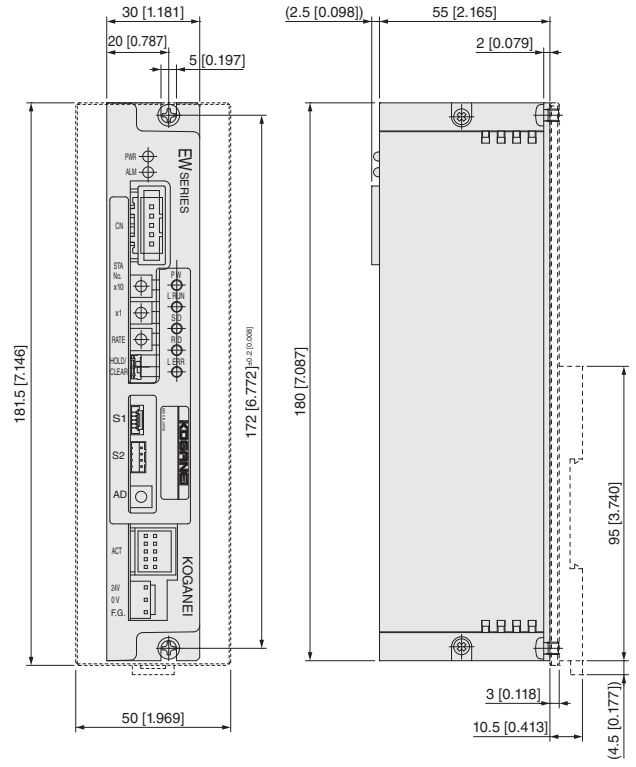

* The dotted lines indicate the dimensions of the DIN rail mounting plate

● DIN rail mounting plate EW2DP

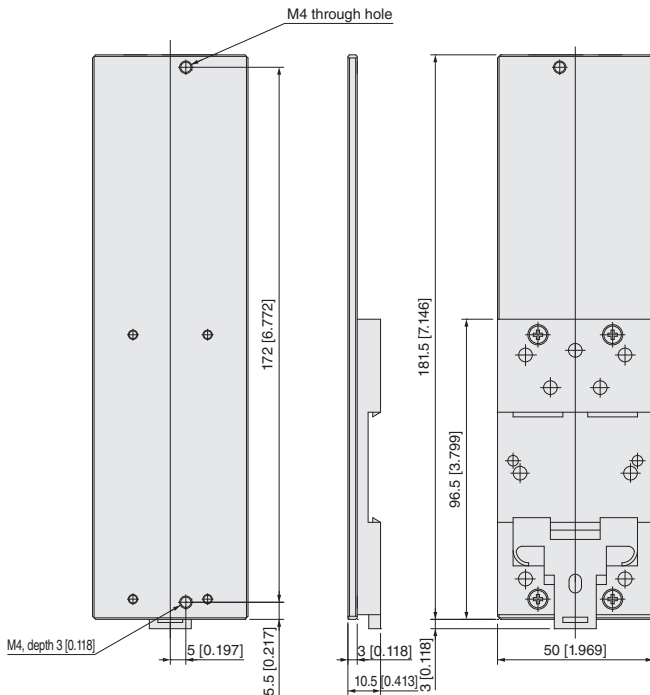
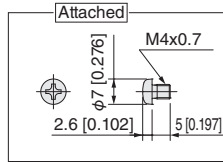

● CC-Link connector EW2CC

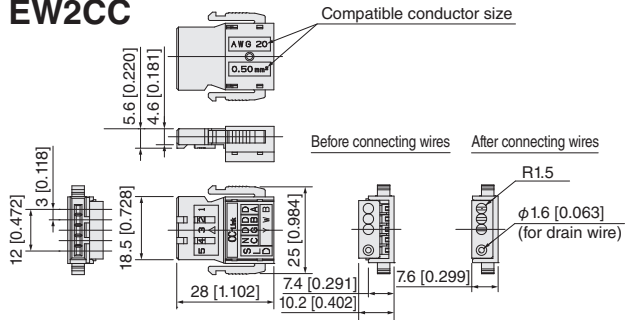

* This connector is compatible with a CC-Link communication cable.

● CC-Link branch connector EW2CY

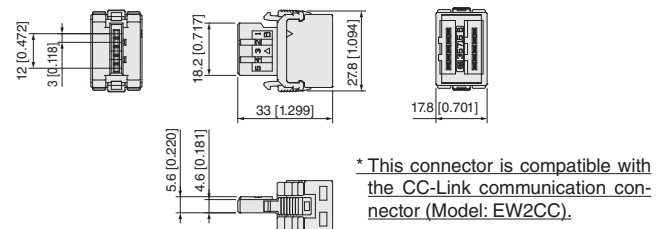

* This connector is compatible with the CC-Link communication connector (Model: EW2CC).

● Terminating resistor (for CC-Link) EW2FC

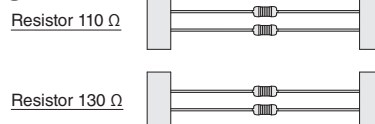

Dimensions (mm [in.])

● Cable (robot cable)

• For connection

EW2KA -

3L: 3 m [9.840 ft]
5L: 5 m [16.400 ft]

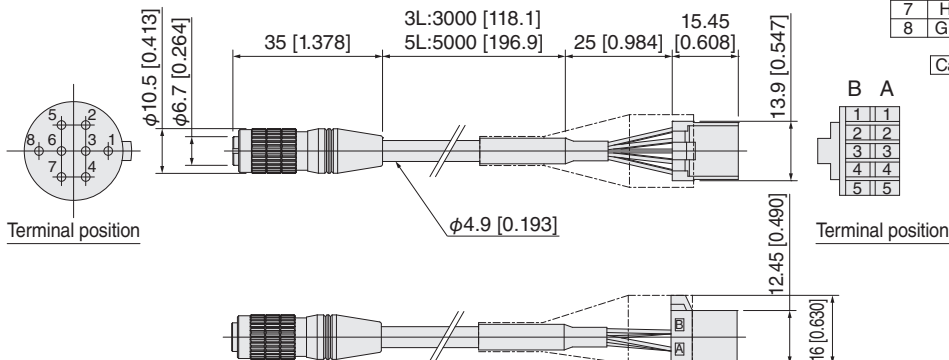

Main unit side connector			Controller side connector		
NO.	Name	Color	NO.	Name	Color
1	U	Green	A1	U	Green
2	V	Brown	B1	V	Brown
3	W	Yellow	A2	W	Yellow
4	Vcc	Orange	B2	FG	White
5	HU	White	A3	Vcc	Orange
6	HV	Red	B3	GND	Blue
7	HW	Black	A4	HU	White
8	GND	Blue	B4	HV	Red
			A5	HW	Black
			B5	N.C.	-

Cable shield

B A



Terminal position

• For power supply

EW2KP

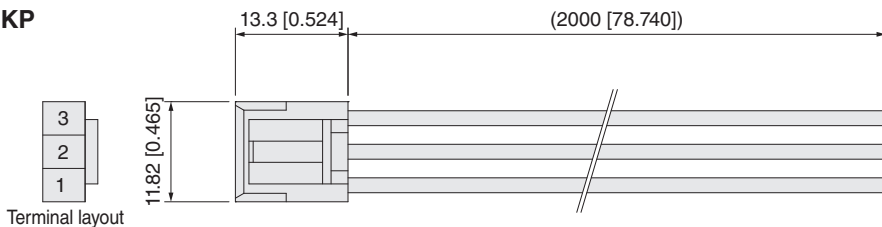

Power connector terminal layout

NO.	Name	Color
1	24V	Red
2	GND	Blue
3	F.G.	Green

• For I/O

EW2KI

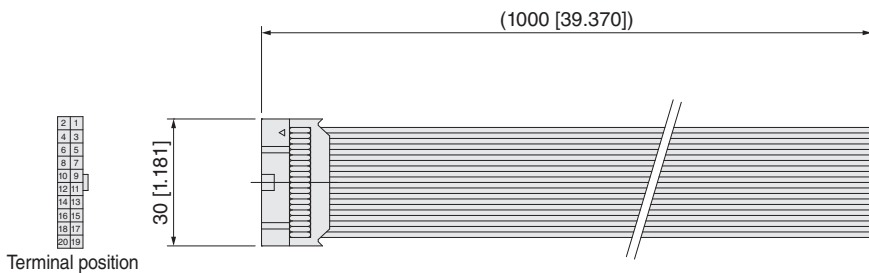

I/O connector terminal layout

NO.	Name	Color
1	POS0	Brown
2	POS1	Red
3	POS2	Orange
4	POS3	Yellow
5	POS4	Green
6	START	Blue
7	STOP	Purple
8	ORG	Gray
9	RDY	White
10	BUSY	Black
11	INPOS	Brown
12	HOLD	Red
13	24G IN	Orange
14	N.C.	Yellow
15	24G	Green
16	24V IN	Blue
17	N.C.	Purple
18	24V	Gray
19	F.G.	White
20	F.G.	Black

• For daisy chain (for RS485 communication)

EW2KD -

008L: 80 mm [3.150 in.]
1L: 1 m [3.280 ft]
3L: 3 m [9.840 ft]

Cable layout chart

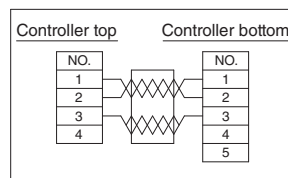

Connector terminal layout (controller top)

NO.	Name	Color
1	A	Brown
2	B	Blue
3	GND	Black
4		

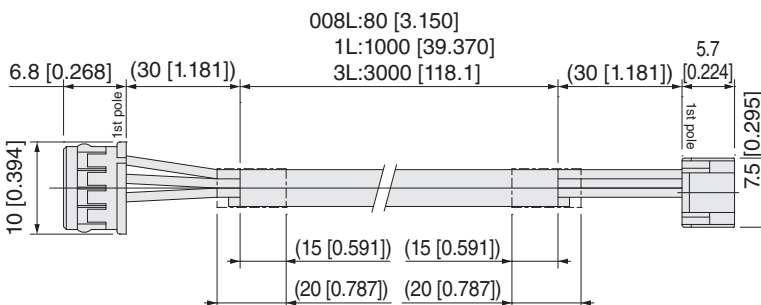

Connector terminal layout (controller bottom)

NO.	Name	Color
1	A	Brown
2	B	Blue
3	GND	Black
4		
5		

Dimensions (mm [in.])

- For communications (for RS485 communication)

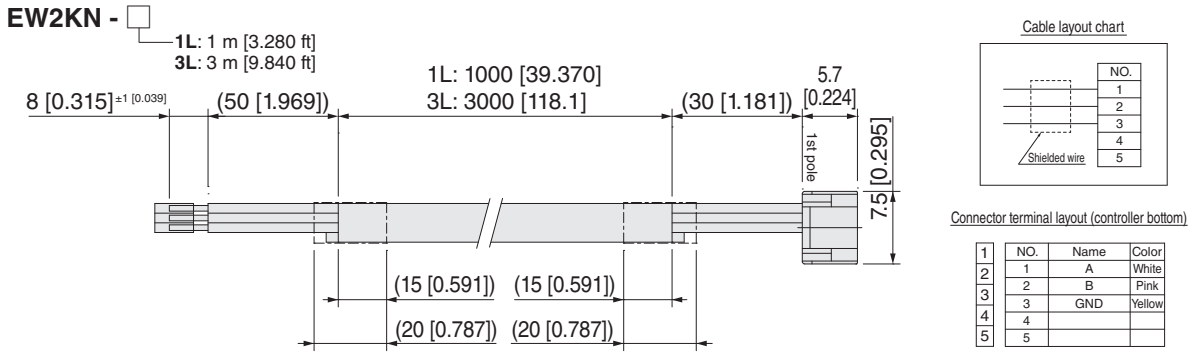

- USB-RS485 converter for communication

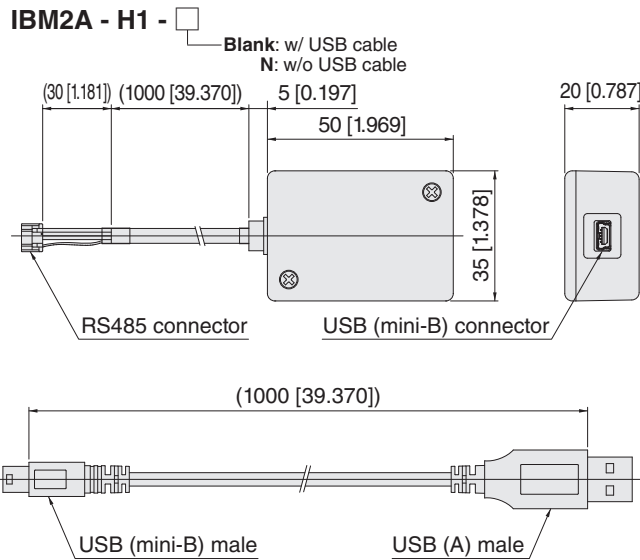

- Terminating resistor (for RS485 communications)

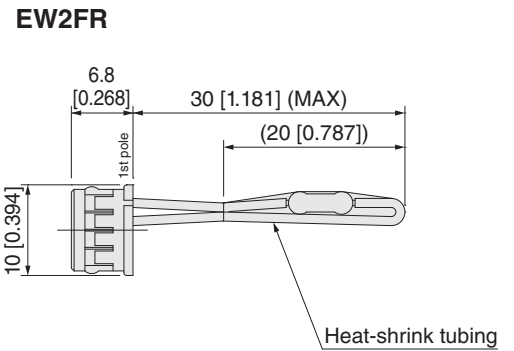

- Connecting cable (loose wires) for main unit* (robot cable)

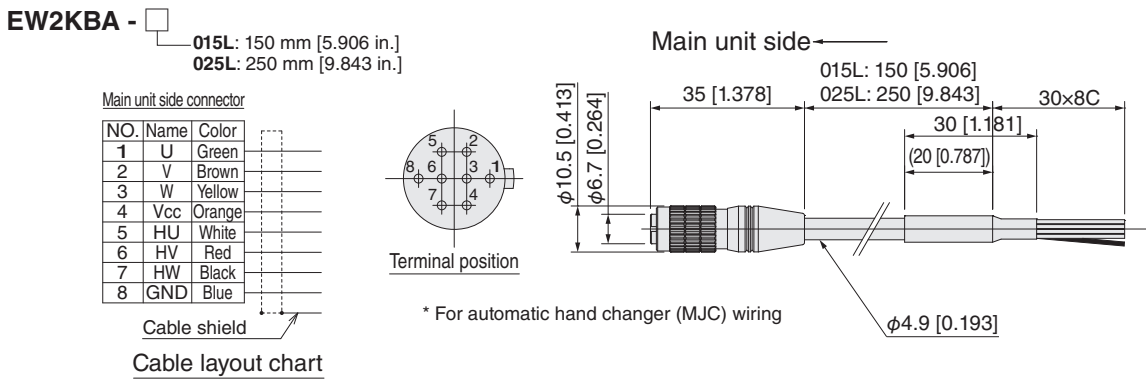

- Connecting cable (loose wires) for controller* (robot cable)

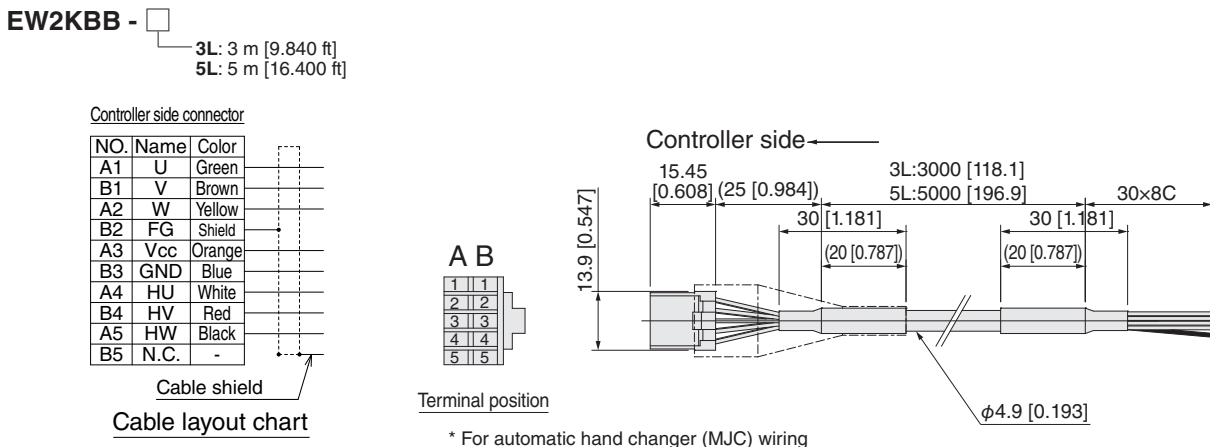

Low Profile Electric Slider and controller correspondence table

Additional parts models		Controller					Teaching box		Connecting cable	
		EW2C-H-NP EW2C-H-PN	EW2C-H-CC EW2C-H-CCD	EWHC(P)-NH	EWHC(P)-RA	EWHC(P)-RS	EW2TB	EWHTB	EW2KA	EWHKA
Actuator model										
Low Profile Electric Slider	EW2G10	○	○	-	-	-	○	-	○	-
	EW2G12	○	○	-	-	-	○	-	○	-
	EW2G16	○	○	-	-	-	○	-	○	-

Selection Procedure

- Low Profile Electric Slider
- Thrust

Note: The following thrust ranges are just for reference.

Note: They indicate the thrust with the product installed horizontally.

Note: When the product is installed vertically, the thrust may not increase depending on the pushing level and load conditions.

EW2G10H

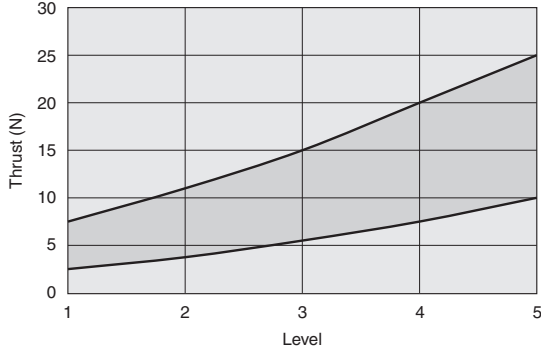

EW2G10S

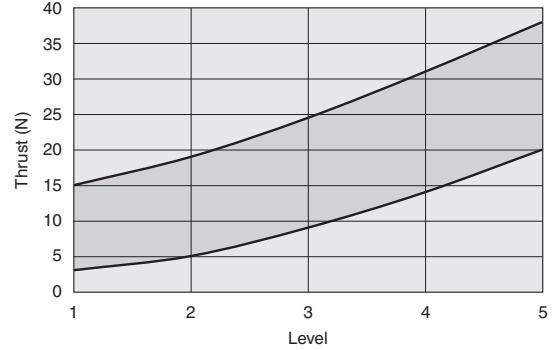

EW2G12H

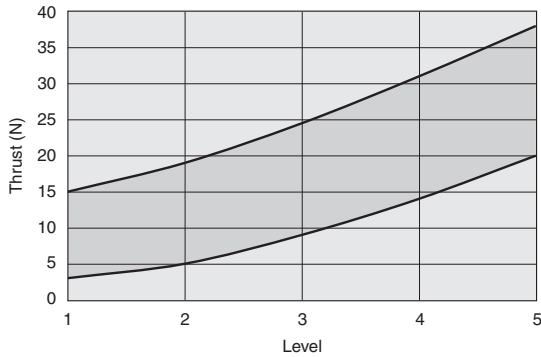

EW2G12S

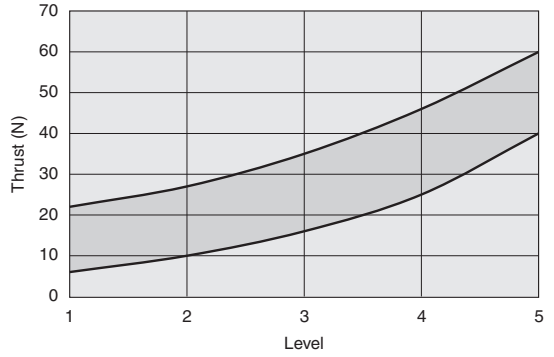

EW2G16H

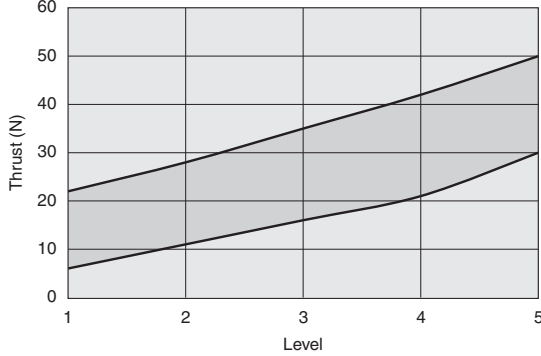

EW2G16S

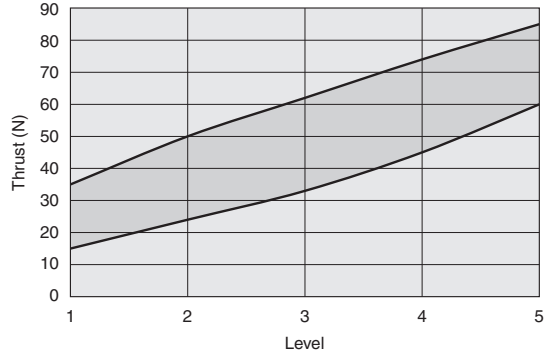

● Operation modes of low profile electric slider (for point input type controller)

Mode	Positioning		Pushing		Pushing with acceleration/deceleration movement
	Moves to the specified point with acceleration/deceleration, and then stops.		Operates at constant speed, and pushes at the set force.		Performs pushing operation during acceleration/deceleration movement.
Setting value	A	I ^{Note 1}	C	O	U
Description	Moves to the specified point position in the coordinate system where the origin is 0	Moves from the current position to the specified point position	Operation to OUT-side	Operation to IN-side	Operates to the specified point, and performs pushing operation at the speed set in PRM7 from the distance forward of the point set in PRM8
Operation pattern					
Remarks	—		—		Suitable for soft gripping with high cycle operation.

Note 1: If the tooling is moved manually and then operated in mode I, the tooling is operated by using the position before it was moved manually as a reference position.

Note 2: The workpiece must be pushed in pushing mode (C or O) or in pushing mode (U) with acceleration/deceleration movement. If the workpiece is pushed in positioning mode (A or I), an alarm is output, and the workpiece cannot be pushed normally.

Selection Procedure

● Low Profile Electric Slider System Configuration Diagrams (Examples)

● Point input type controller

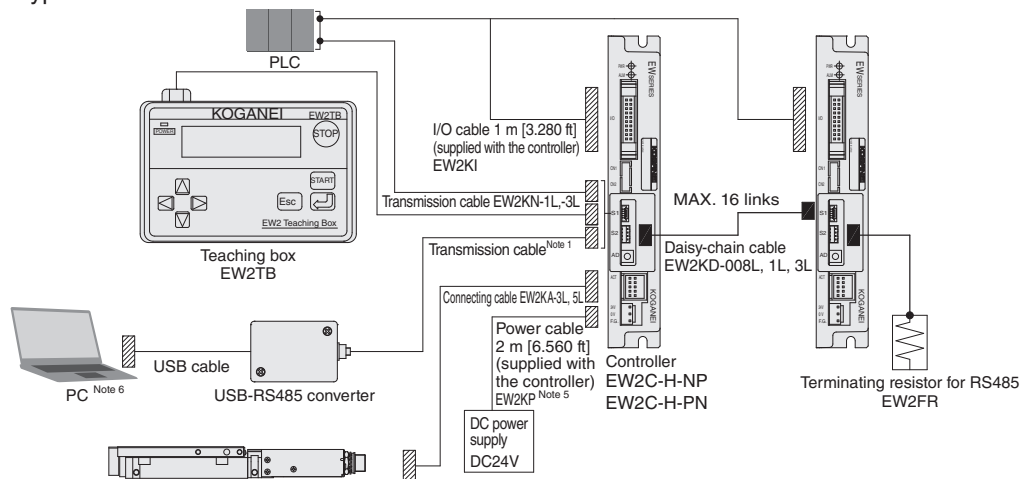

● CC-Link type controller ①

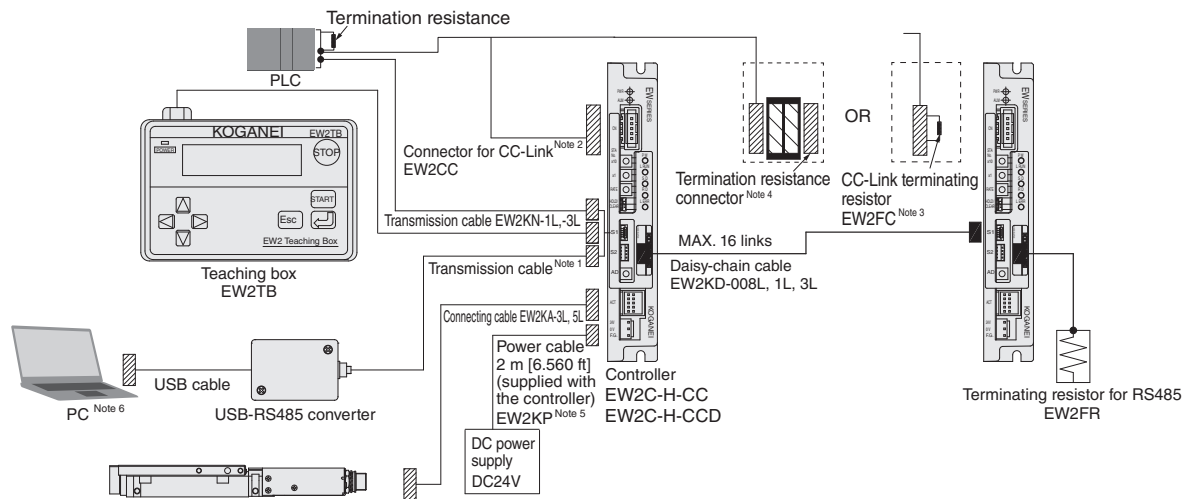

● CC-Link type controller ②

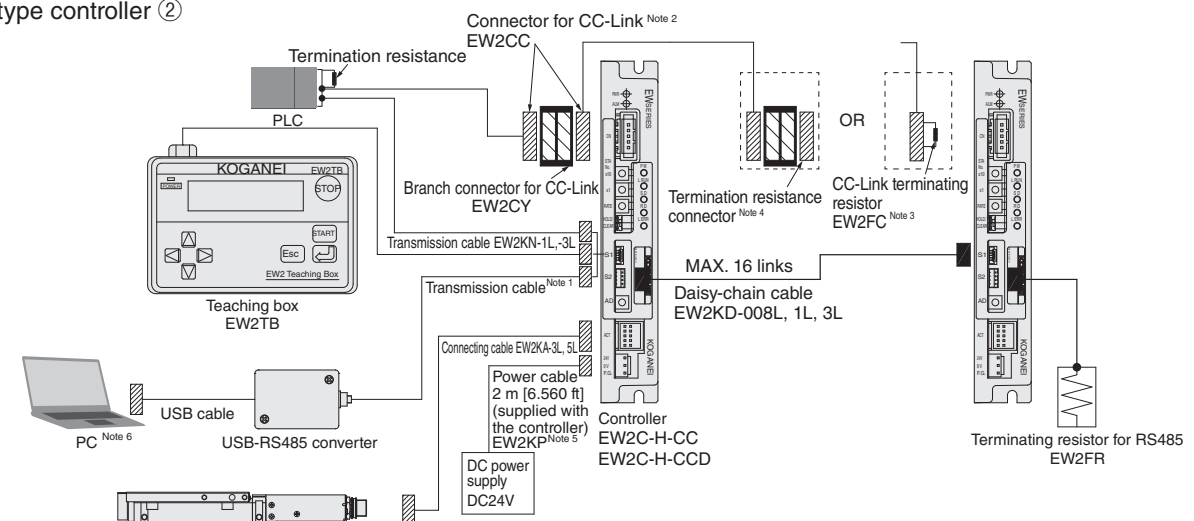

Note 1: The communication cable is selectable from the following.

- IBM2A-H1 : USB-RS485converter, w/ USB cable
- IBM2A-H1-N: USB-RS485 converter, w/o USB cable
- EW2KN : For communication

2: Only the CC-Link connector is provided. The cable must be prepared by the customer. (Ver.1.1-compatible CC-Link dedicated cable)

3: If EW2C-H-CC□ is used as the termination unit, be sure to use a CC-Link terminating resistor (EW2FC) or terminating resistor connector.

4: The terminating resistor connector must be prepared by the customer.

[Recommendation] 35T05-6M00-B0M GF, manufactured by 3M

5: It is recommended to install a noise filter.

(Refer to page ⑦.)

6: The controller setting support software can be downloaded for free from our homepage.

Teaching box

EW2TB

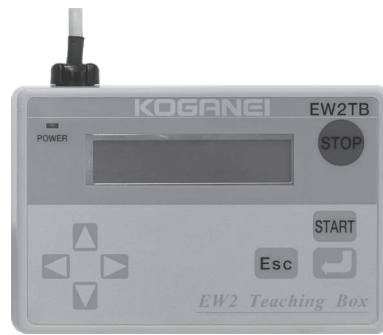

Specifications

Item	Model	EW2TB
Power supply	Power supply voltage	DC24V (supplied by controller)
	Consumed current	50mA MAX.
Indication	Settings display	LCD 16 characters x2 lines
	Power supply indication	At power on, LED lights (5 V internal)
General	Setting method	Key operations: 8 buttons
	Communication method	RS485 (serial communications)
	Cable length	3 m [9.840 ft]
	Mass	Main unit: 200 g [7.05 oz]
	Operating temperature	0 to 40°C [32 to 104°F]
	Operating humidity	35 to 80% RH (no condensation)
	Storage temperature	-10 to 65°C [14 to 149°F]

Teaching box dimensions (mm [in.])

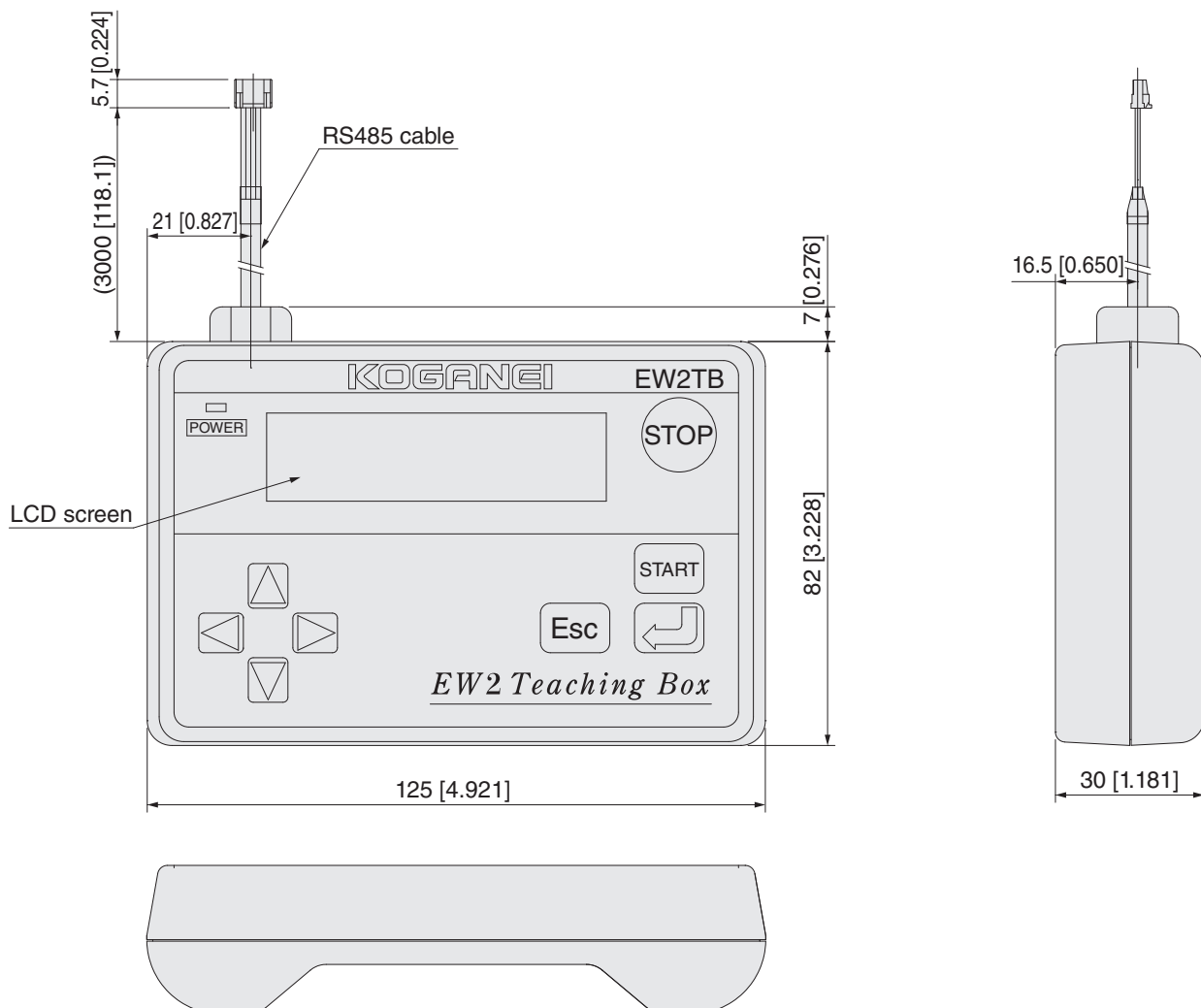

Limited Warranty

KOGANEI CORP. warrants its products to be free from defects in material and workmanship subject to the following provisions.

Warranty Period The warranty period is 180 days from the date of delivery.

Koganei Responsibility If a defect in material or workmanship is found during the warranty period, KOGANEI CORP. will replace any part proved defective under normal use free of charge and will provide the service necessary to replace such a part.

Limitations

- This warranty is in lieu of all other warranties, expressed or implied, and is limited to the original cost of the product and shall not include any transportation fee, the cost of installation or any liability for direct, indirect or consequential damage or delay resulting from the defects.

- KOGANEI CORP. shall in no way be liable or responsible for injuries or damage to persons or property arising out of the use or operation of the manufacturer's product.

- This warranty shall be void if the engineered safety devices are removed, made inoperative or not periodically checked for proper functioning.

- Any operation beyond the rated capacity, any improper use or application, or any improper installation of the product, or any substitution upon it with parts not furnished or approved by KOGANEI CORP., shall void this warranty.

- This warranty covers only such items supplied by KOGANEI CORP. The products of other manufacturers are covered only by such warranties made by those original manufacturers, even though such items may have been included as the components.

The specifications are subject to change without notice.

URL <http://www.koganei.co.jp>

E-mail: overseas@koganei.co.jp



KOGANEI CORPORATION

OVERSEAS DEPARTMENT

3-11-28, Midori-cho, Koganei City, Tokyo 184-8533, Japan
Tel: 81-42-383-7271 Fax: 81-42-383-7276

KOGANEI INTERNATIONAL AMERICA, INC.

48860 Milmont Drive, suite 108C, Fremont, California 94538
Tel: 1-510-744-1626 Fax: 1-510-744-1676

SHANGHAI KOGANEI INTERNATIONAL TRADING CORPORATION

Room 2606-2607, Tongda Venture Building No.1, Lane 600, Tianshan Road,
Shanghai, 200051, China
Tel: 86-21-6145-7313 Fax: 86-21-6145-7323

TAIWAN KOGANEI TRADING CO., LTD.

Rm. 2, 13F., No88, Sec. 2, Zhongxiao E. Rd., Zhongzheng Dist., Taipei City 100,
Taiwan (ROC)
Tel: 886-2-2393-2717 Fax: 886-2-2393-2719

KOGANEI KOREA CO., LTD.

6F-601, Tower Bldg., 1005, Yeongdeong-dong, Giheung-gu, Yongin-si, Gyeonggi-do,
446-908, Korea
Tel: 82-31-246-0414 Fax: 82-31-246-0415

KOGANEI (THAILAND) CO., LTD.

555 Rasa Tower 1, 12th Floor, Unit 1202 and 1207, Phaholyothin Road,
Chatuchak, Chatuchak, Bangkok 10900 Thailand
Tel: 66-2-937-4250 Fax: 66-2-937-4254

KOGANEI AUTOMATION (MALAYSIA) SDN.BHD.

Suite 29-2, Level 29, Menara 1MK, No.1, Jalan Kiara, Mont Kiara
50480, Kuala Lumpur, Malaysia
Tel: 60-12-537-7086

KOGANEI ASIA PTE. LTD.

69 Ubi Road 1, #05-18 Oxley Bizhub, Singapore 408731
Tel: 65-6293-4512 Fax: 65-6293-4513